

SUBDIVISION REGULATIONS
&
DESIGN AND CONSTRUCTION
STANDARDS
PLANNING BOARD
OF THE
TOWN OF SARATOGA, NEW YORK

Prepared by
Planning Board
of the
Town of Saratoga

By authority of the resolution adopted by the Town Board on the 11 day of September 1972, pursuant to the provisions of Article 16 of the Town Law, the Planning Board of the Town of Saratoga is empowered and authorized to approve plats for land subdivision within the Town outside the limits of any incorporated village. These regulations and design and construction standards are adopted for the purpose of providing for the future growth and development of the Town and affording adequate facilities for the housing, transportation, distribution, comfort, convenience, safety, health and welfare of its population.

	<u>Page</u>
PART I - SUBDIVISION REGULATIONS	
Section I - Definitions	11
Section II - Procedure	13
Section III - Preapplication Conference	16
Section IV - Preliminary Submission	17
Section V - Final Submission	18
Section VI - Inspection of Construction and "As-Built" Drawings	20
Section VII - General Requirements for the Subdivision of Land	20
Section VIII - Required Improvements	24
Section IX - Variances and Modifications	24
Section X - Separability	24
 PART II - SUBDIVISION DESIGN AND CONSTRUCTION STANDARDS	
Section I - Introduction	1
Section II - Design Standards	1
1. Surveying and Mapping	1
1.0 General	1
1.1 Surveying Accuracy	1
1.2 Mapping Accuracy	2
1.3 Monuments and Bench Marks	2
1.4 Certification	2
2. Streets	2
2.0 General	2
2.1 Street Width	2
2.2 Street Alignment	3
2.3 Street Grades	3

2.	Streets (cont.)	
2.4	Street Intersections	3
2.5	Dead End Streets	4
2.6	Street Access	4
2.7	Street Setbacks	4
2.8	Fill Slopes	4
2.9	Guide Railings	5
3.	Storm Drainage	5
3.0	General	5
3.1	Design Criteria	5
3.2	Pipe	5
3.3	Catch Basins and Manholes	6
3.4	Trash Racks	6
3.5	Grading	6
4.	Sanitary Sewerage	6
4.0	General	6
4.1	Collection System	7
4.2	House Service	7
5.	Water System	7
5.0	General	7
5.1	Water Supply	7
5.2	Water Quality	7
5.3	Hydro-Pneumatic Pressure System	7
5.4	Chlorination	8
5.5	Water Mains	8
5.6	Valves	8
5.7	Hydrants	8
5.8	Services	8
	Section III - Construction Standards	8
1.	General Construction Practices	8
1.0	General	8
1.1	Maintenance and Protection of Traffic	9
1.2	Clean Up and Repair	9
1.3	Restoration of paved Street Surfaces	9
1.4	Land for Public Usage	9
1.5	Construction Modification in Field	9

2.	Roadway Construction	10
2.0	General	10
2.1	Subbase Preparation	10
2.2	Embankment	10
2.3	Base Construction	10
2.4	Surface Construction	10
2.5	Curbs	11
2.6	Portland Cement Concrete	11
2.7	Underdrains	11
3.	Storm Drainage System	11
3.0	General	11
4.	Sanitary Sewerage System	11
4.0	General	11
4.1	Maintaining Existing Service	11
4.2	House Service	11
4.3	Tests	12
	Infiltration Tests	
	Exfiltration Tests	
	General	
5.	Water System	12
5.0	General	12
5.1	Watermains	13
	a. Handling	13
	b. Cutting	13
	c. Placing and Laying	13
	d. Mechanical Joints	13
	e. Slip-Type Joints	13
	f. Anchoring	13
	g. Testing	14
	h. Disinfection	14
5.2	Valves	14
5.3	Hydrants	14
5.4	Services	15

6.	Pipeline Construction	15
6.0	General	15
6.1	Pipe	15
6.2	Excavation General	15
6.3	Rock Excavation	17
6.4	Lines and Grades	17
6.5	Bedding	17
	a. First Class Bedding	17
	b. Concrete Cradle Bedding	18
	c. Concrete Encasement	18
6.6	Pipe Laying	18
6.7	Backfilling	19
6.8	Tunnels	19
6.9	Jacking and Boring	20
6.10	Manholes and Catch Basins	20
6.11	Connections	20
7.	Plain and Reinforced Concrete	21
7.0	General	21
7.1	Materials	21
	a. Cement	21
	b. Aggregate	21
	c. Mixing Water	21
7.2	Quality of Concrete	21
	a. Class of Concrete	21
	b. Water Cement Ratio	21
	c. Concrete Proportions & Consistency	22
7.3	Tests on Concrete	22
	a. Sampling	22
	b. Slump Test	22
	c. Compression Test	22
7.4	Mixing and Placing Concrete	23
	a. Preparation of Equipment and Place of Deposit	23
	b. Mixing of Concrete	23
	c. Conveying of Concrete	23
	d. Placing of Concrete	23
	e. Curing of Concrete	24
	f. Cold Weather Concreting	24
	g. Hot Weather Concreting	24
	h. Forms	25
	i. Placing and Splicing of Reinforcement	25

8. Cable and Conduit	25
8.0 General	25
8.1 Sequence of Construction	25
8.2 Conduit	26
8.3 Identification	26
8.4 Documentation	26

PART III - SUBDIVISION STANDARD DRAWINGS.

PART IV - APPROVED MATERIALS FOR SUBDIVISION
CONSTRUCTION

PART I

SUBDIVISION REGULATIONS

For the purpose of these regulations, the following words and terms shall have the meanings indicated:

"Board"

Means the Planning Board of Town of Saratoga or any person authorized by the Planning Board to act as its representative.

"Construction"

Refers to paving, utility and miscellaneous construction in public rights-of-way or easements as shown on the subdivision Development Map and not privately owned construction covered by building permits.

"Double Frontage Lots"

Are lots with the rear and front lot lines abutting existing or proposed streets.

"Final Plat"

Means the final map upon which the owner's plan of subdivision is presented to the Planning Board for approval, and which, if approved, shall be submitted to the county clerk, town clerk and town assessor for recording. The Final Plat shall be submitted as part of the Final Submission.

"Final Review"

Refers to the complete process of reviewing a Final Submission and issuing a final approval or disapproval by the Board.

"Final Submission"

Refers to the Final Plat and all other documents the subdivider is required to submit for Final Review of a Subdivision by the Board.

"Half-Streets"

Are those that are less than full width, in either paving or right-of-way.

"Letter of Credit"

Is a letter taken out by the owner from a bank which guarantees the Town that a specific amount of money will be kept available for the completion of a subdivision construction to be drawn on only by the Town.

"Master Plan"

Is a comprehensive plan for the development of the Town as authorized in Section 272-a of the Town Law.

"Official Map"

Is a map established by the Town Board under Section 270 of the Town Law, showing the streets, highways and parks theretofore laid out, adopted and established by law and all changes or additions thereto made under the provisions of the Town Law.

"Owner"

Means the owner of the land proposed to be subdivided, or his agent.

"Performance Bond"

An obligation in writing, under seal, issued by a Surety Company satisfactory to the Town Board binding the obligor to pay a sum of money to the Town if the obligor fails to satisfactorily install and/or maintain improvements as required by Town Law Saratoga.

"Preliminary Plat"

Means a drawing showing the salient features of a proposed subdivision submitted to the Planning Board for its consideration prior to submission of the Final Plat. The Preliminary Plat is submitted as part of the Preliminary Submission.

"Preliminary Review"

Refers to the complete process of reviewing a Preliminary Submission and issuing an approval, approval with modifications, or disapproval by the Board.

"Preliminary Submission"

Refers to the Preliminary Plat and all other documents required for Preliminary Review of a Subdivision by the Board.

"Reverse Frontage Lots"

Are lots with the rear lot line abutting an existing or proposed street.

"Roadway"

Refers to the portion of a street which is designated for vehicle use.

"Subdivision"

Is the division of any parcel of land into two or more lots, sites or other divisions of land for immediate or future sale or for building development whether or not the subdividing creates a street. The term "Subdivision" is used to denote the act of subdividing or the property which is subdivided.

"Street"

Means a way for vehicular traffic, whether designated as a street, highway, thoroughfare, parkway, thruway, road, avenue, boulevard, lane, cul-de-sac, place or however otherwise designated and includes the entire area within the right-of-way.

- a. Arterial streets and highways are those used or destined to be used primarily for fast or heavy traffic whether existing or proposed.
- b. Collector streets are those which carry traffic from minor streets to the major system of arterial streets and highways. Collectors may also serve as secondary arteries to carry some through traffic. A street which is the outlet toward an arterial street for more than 100 acres or is a main entrance to a residential development shall be considered a collector street.
- c. Local streets are those which are used primarily for access to the abutting properties.
- d. Marginal access streets are minor streets which are parallel to and adjacent to arterial streets and highways and which provide access to abutting properties and protection from through traffic.

"Town"

Means the Town Board of Saratoga, Highway Superintendent of Saratoga or other official responsible by law for the function referred to. It may also refer to the person authorized to act as the representative of the responsible official or officials.

Section II - Procedure

General: Whenever a time limit is specified in these regulations, the board may extend the limit upon request by the Owner provided the Board is legally empowered to do so.

When any Subdivision of land is proposed to be made within the unincorporated sections of the Town and before any contract for the sale of, or any offer to sell, such subdivided land, or any part thereof, is made, and before any construction is begun, and before any building permit shall be granted, the owner shall submit his Subdivision for review by the Planning Board.

Two methods of completing subdivision construction are provided in accordance with Town Law Section 277. The Owner may install improvements prior to Final Approval and submit a Letter of Credit or performance bond at the time of Final Submission, in an amount approved by the Town, to cover the cost of those improvements prior to Final Approval and submit such a Letter of Credit or performance bond to cover the cost of all improvements.

Four steps are prescribed for the subdivision review process. The entire process is described in this section and the detailed requirements of each step are described in Sections III, IV, V, and VI.

Step One, Pre-application Conference: The purpose of this step is to determine feasibility of the project before the Owner has invested a substantial amount of money. The Owner shall present such information as the Board may require. The Board will inform the Owner of general Subdivision requirements as well as particular requirements for the Subdivision under review as dictated by the Master Plan, Official Map or other considerations.

Step Two, Preliminary Review: The Owner shall present a Preliminary Submission at a Planning Board meeting. The date of the Preliminary Submission shall be the date of the meeting at which it is presented.

A field walk by the Board with the Owner may be required. Temporary stakes showing street centerlines may be required.

The Board shall hold a public hearing on the proposed Subdivision within 45 days of the date of the Preliminary Submission. Notice of such public hearing shall be advertised in a newspaper of general circulation in the Town at least five days before such hearing.

The Board shall communicate to the Owner in writing within 45 days after the public hearing, its decision concerning the Preliminary Submission. If the Preliminary Submission is approved, the Board shall express its approval with or without modifications, if any, which shall be required in the Final Submission. If modifications are required, the reasons therefore shall be given.

If the Owner elects to begin construction before Final Submission, he may begin all construction provided he has indicated this intention to the Town, except the one inch (1 ") double surface treatment after approval in accordance with the approval or approval with modifications.

If the Preliminary Submission is disapproved, the Board will state the reasons for its disapproval.

The action of the Board shall be noted on two (2) copies of the Preliminary Submission form, to which shall be attached reference statements of any conditions and requirements determined by the Board. One copy shall be returned to the Owner and the other retained by the Board.

If the Preliminary Submission is disapproved resubmissions may be made within six months of the date of disapproval with no additional fee required. A resubmission made after six months from the date of disapproval may be treated like a new submission and require a new Preliminary Review and fee.

Step Three, Final Review: If the Preliminary Submission is approved, the Owner within six months of the date of approval shall present a Final Submission at a Planning Board Meeting.

In the event that a Final Submission of the entire subdivision or part of it is not made within six months from the date of approval, the application may be considered withdrawn and any approved modifications or waivers of required improvements by the Board may be considered lapsed.

The date of the Final Submission shall be the date of the meeting at which it is presented.

The Final Submission shall conform to the approved Preliminary Submission and shall contain any modifications specified by the Board. If desired by the Owner, it may include only that portion of the approved Preliminary Plat which he proposes to record and develop at that time, provided that such portion conforms to all requirements of these regulations.

The Owner shall submit a Letter of Credit or Performance Bond at the time of Final Submission to cover street pavement wearing coarse construction and all other construction which has not been completed and approved by the Town plus 20% of that construction which has been completed and approved. The amount of the Letter of Credit shall be determined by a construction Cost Estimate prepared by the Owner.

The Board shall hold a public hearing on the proposed subdivision within 45 days of the date of the Final Submission. Notice of such public hearing shall be advertised in a newspaper of general circulation in the Town at least five days before such hearing.

Within 45 days from and after the time of the public hearing, the Board shall approve, modify and approve, grant conditional approval, or disapprove, the Final Submission and communicate its decision to the Owner in writing.

Under certain conditions the Board may waive this second hearing (Section 276 Town Law). In the event the hearing is waived, Board action shall be within 45 days of submission.

If the Final Submission is approved by the Board, an appropriate notation to that effect shall be made on the face of the original or tracing cloth prints of the Final Plat submitted to the Board. The copy shall be returned to the Owner and one copy shall be retained by the Board for its records.

The Owner shall file the approved Final Plat with the county clerk within 30 days after approval by the Board. If the Final Plat is not filed within this time, the approval shall expire, as provided in Section 276 of the Town Law.

The Owner may obtain building permits and begin building construction only after filing of the Final Plat.

If the Final Submission is disapproved, resubmissions may be made within six months of the date of disapproval with no additional fee required. A resubmission made after six months from the date of disapproval may be treated like a new submission and require a Final Review and fee.

Step Four - Final Inspection and "As-Built" Drawings: Upon approval of the Final Submission and after construction of houses is substantially completed, the Owner shall construct the street pavement wearing course in accordance with the Final Approval and the Subdivision regulations at a time authorized by the Town. Minor changes from the development map and plan/profiles as required by conditions of the work site may be allowed in the actual construction.

Upon completion of construction a final inspection shall be held by the Town. When construction has been approved, final plats and plan/profiles shall be corrected by the Owner to show all construction "As Built". The Letter of Credit or Performance Bond may be reduced by the Town as construction progresses. It shall not be reduced to less than the amount determined for that construction which is still uncompleted, plus 20% of the amount determined for that construction which is completed and approved. It shall be kept in effect for one year after the final inspection. It shall then be released provided the Owner has prepared "As Built" plans.

Exception: In the review of a Subdivision which includes no new roads and includes no more than four new lots, any or all of the steps except Final Review may be waived by the Board. The Board may also waive all fees and any of the requirements of the Final Review which are not required for legality.

Section III - Preapplication Conference

The preapplication conference may take place at any time acceptable to the Board.

The Owner shall furnish three copies of a sketch plan of the proposed Subdivision and all adjacent land owned by the Owner or under option to him. The sketch shall include a street layout and drainage plan. The sketch shall be to a scale not less than 100 feet per inch. One additional copy of the sketch plan shall be submitted to the Saratoga County Soil and Water Conservation District for its review and recommendations to the Planning Board.

The Planning Board shall advise as to feasibility and any special considerations for the Subdivision design. A field walk with the Owner may be required.

Section IV - Preliminary Submission

If construction is to precede Final Review three prints of the Plat, development map and plan/profiles shall be submitted which meet the requirements for Final Submission. One additional copy of the sketch plan shall be submitted to the Saratoga County Soil and Water Conservation District for its review and recommendations to the Planning Board.

The Preliminary Submission shall include the following in triplicate:

1. Preliminary Plat to a scale not smaller than 50 feet to the inch drawn accurately to scale with approximate dimensions shown and including all the information required for a Final Plat except monuments and iron pipes and the certification of standards of accuracy.
 - a. In addition, highways or other major public or private improvements planned for future consideration on or near the proposed subdivision, including those shown on the Official Map or Master Plan shall be shown.
 - b. All contiguous land owned or under option by the Owner shall be shown with a street and lot plan for its development.
 - c. Water elevations and subsurface information including groundwater elevation shall be noted where appropriate.
2. Plan/profile for each street with a horizontal scale of 40 feet to the inch and vertical scale of four feet to the inch showing all the information required for the Final Submission of a plan/profile except that approximate stationing may be shown. In addition, profiles of present surface shall be shown on centerline and both right-of-way lines of all streets and on centerline of all easements.
3. All sheets shall not be smaller than 8½" X 14", nor larger than 30" X 42". All maps must be printed or drawn with pen and India Ink upon transparent tracing cloth or polyester film or be photographic copies on transparent tracing cloth or polyester film and further that said maps shall be not less than 8½" X 14" nor more than 30" X 42" in size.
4. In addition to the required drawings the following information shall be submitted as part of the Preliminary Submission.
 - a. Completed Town of Saratoga Preliminary Submission form.
 - b. Request for any zoning changes proposed for the area to be subdivided, if applicable.
 - c. Conditions of dedication of areas proposed to be dedicated to public use.
 - d. Preliminary designs of bridges and culverts (final designs if construction is to precede Final Review).

2. Draft of any protective covenants whereby the Owner proposes to regulate land use in the Subdivision and otherwise protect the proposed development.

More detailed information may be required by the Planning Board as a part of the Preliminary Submission in special cases.

Section V - Final Submission

This submission shall include the following:

1. Final Plat, including two copies drawn in ink on tracing cloth or black line prints on reproducible permanent material acceptable to the Board plus five prints to a scale not smaller than 50 feet to the inch showing the following:
 - a. All existing and proposed property lines, building setback lines, easement and right-of-way lines with dimensions, azimuths or angle data, and curve data.
 - b. All monuments, iron pipes and bench marks.
 - c. Names of owners of all adjacent property.
 - d. Street names.
 - e. All property reserved by the owner or dedicated to public use.
 - f. A house number for each lot.
 - g. A north arrow.
 - h. Standard title block.
 - i. Key map.
 - j. Proposed use of each lot.
 - k. Standards of accuracy meeting Saratoga requirements shall be noted on the map and certified by a land surveyor registered in New York State.
 - l. Contour lines at two foot intervals to U.S.G.S. datum.
 - m. Watercourses, marshes, rock outcrops and other important land features.
 - n. Right-of-way lines, street paving and street stationing.
 - o. Sanitary sewers, storm drains, gas lines and waterlines with all appurtenances.

- p. Street name signs (A Letter of Intent to install signs in locations approved by the Town may be accepted as a substitute.)
 - q. Standards of accuracy of elevations meeting Saratoga requirements shall be noted on the map. The final plat shall contain the signature and seal of a professional engineer registered in New York State or a qualified Land Surveyor under Section 7208 paragraph n of the Education Law.
2. Plan/profile of each street and utility easement, including one copy drawn in ink on tracing cloth or black line print on reproducible permanent material acceptable to the Board plus five prints, with a horizontal scale of 40 feet to the inch and a vertical scale of four feet to the inch showing the following:
 - a. All pavement, storm drains, sanitary sewers, gas lines and water lines with appurtenances.
 - b. Pavement and utility stationing including all horizontal and vertical control points and grades.
 - c. Signature and seal of a professional engineer registered in New York State or a qualified Land Surveyor under Section 7208 paragraph n of the Education Law.
 - d. A north arrow.
 - e. Standard title block.
 3. Final Plat and plan/profiles shall show all facilities which the subdivision standards require. All lettering shall be neat and legible.
 4. All sheets shall not be smaller than 8½" X 14" nor larger than 30" X 42". When more than one layout sheet is required all shall be the same size, and an index sheet of the same size shall be provided showing the entire subdivision to an appropriate scale.
 5. In addition to the required drawings, the following documents shall be submitted as part of the Final Submission.
 - a. Completed Town of Saratoga Final Submission form.
 - b. Offer of cession in a form approved by the Board of all land included in streets, walks, easements and recreation areas not specifically reserved by the Owner. If required by the Board there may be a payment in lieu of the offer of recreation areas. Approval of the plat does not constitute acceptance of the offer of cession.
 - c. Certificate of adequacy of the proposed water supply and sewerage service as required by the Public Health Law of New York State and/or the Saratoga Co. Health Department if applicable, and/or the Environmental Conservation Department of New York State.

- d. Statement by the appropriate Town representative certifying that certain improvements have been installed and approved.
 - e. Deed description and proof of ownership of the land to be subdivided.
 - f. Protective covenants in form for recording, including covenants governing the maintenance of unceded public spaces or reservations.
 - g. Final design of bridges and culverts unless included in Preliminary Submission.
 - h. Such other certificates, affidavits, endorsements or agreements as may be required by the Planning Board in the enforcement of these regulations.
6. A fee shall be paid with the Final Submission. The fee shall be ten (\$10) dollars per lot but in no case shall the fee be less than \$25.
7. More detailed information may be required by the Planning Board as a part of the Final Submission in special cases.

Section VI - Inspection of Construction and "As-Built" Drawings

Various items of construction may be inspected and approved upon their completion and the amount of the Letter of Credit may be reduced provided it does not become less than the amount described in Step 4 of Section II.

Final Plat and plan/profile shall be corrected as built and one copy drawn in ink on tracing cloth or black line print on tracing cloth or other reproducible permanent material acceptable to the Town plus one print shall be furnished to the Town. Upon approval of "as built" drawings, the Town shall release the Letter of Credit or performance bond provided one year has passed without any construction failure since the Final Inspection.

Section VII - General Requirements for the Subdivision of Land

The Owner shall observe the following general requirements and principles of land subdivision.

Streets

1. The arrangement, character, extent, width and location of all streets shall conform to the Master Plan and to the Official Map, if any, and shall be considered in their relation to other existing and planned streets, to topographical conditions, to public convenience and safety, and in their appropriate relation to the proposed uses of land to be served and/or abutted by such streets.

2. Where such is not shown in the Master Plan, the arrangement of streets in a Subdivision shall either:
 - a. Provide for the continuation or appropriate projection of existing principal streets in surrounding areas; or
 - b. Conform to a plan for the neighborhood approved or adopted by the Planning Board to meet a particular situation where topographical or other conditions make continuance or conformance to existing streets impracticable or undesirable.
3. Local streets shall be so laid out that their use by through traffic will be discouraged.
4. Where a Subdivision abuts or contains an Arterial Street, the Planning Board may require Marginal Access Streets; Reverse Frontage Lots with screen planting contained in a non-access reservation along the rear property line, or such other treatment as may be necessary for adequate protection of residential properties and to afford separation of through and local traffic.
5. Where a Subdivision abuts or contains a railroad right-of-way or controlled access highway right-of-way, the Planning Board may require a street approximately parallel to and on each side of such right-of-way, at a distance suitable for the appropriate use of the intervening land, as for park purposes in residential districts or for commercial or industrial purposes in appropriate districts. Such distances shall also be determined with due regard for the requirements of approach grades and future grade separations.
6. The Board may require that street names be approved by the County Highway Department or the Town Officials designated by the Town Board to avoid duplications or use of similarly sounding or spelled names.
7. Public access shall be provided to streets, water plants, sewage treatment plants or to other land dedicated or to be dedicated to public use.
8. Where a Subdivision is traversed by a water course, there shall be a storm water easement not less than 25 feet in width conforming substantially with the lines of such water course, and such further width or construction, or both, as will be adequate to confine a design storm as specified in the subdivision storm drainage design standards. Parallel streets or parkways may be required in connection therewith.

Blocks and Lots

9. The lengths, widths, and shapes of blocks and lots shall be determined with due regard to:
 - a. Provision of adequate building sites suitable to the special needs of the type of use contemplated.
 - b. Zoning requirements, if applicable.
 - c. Needs for convenient access, circulation, control and safety of street traffic.
 - d. Limitations and opportunities of topography.
 - e. Block length which generally shall not exceed 2,000 feet, nor be less than 600 feet.
 - f. Intersections with Arterial Streets which should be held to a minimum and preferably spaced at least 1,000 feet apart.
 - g. Need for pedestrian walks, not less than 10 feet in width, property line to property line, which shall be required where deemed essential to provide circulation, or access to schools, playgrounds, shopping centers, transportation and other community facilities.
10. Land subject to flooding shall not be platted for residential occupancy nor for such other uses as may increase danger to life or property or aggravate the flood hazard.
11. The subdividing of the land shall be such as to provide, that each lot abut a public street which provides satisfactory access via public streets to an existing public street or highway.
12. Double Frontage and Reverse Frontage Lots should be avoided except where essential to provide separation of residential development from Arterial Streets or other disadvantageous use (see Section VII, paragraph 4), or to overcome specific disadvantages of topography and orientation.
13. Side lot lines shall be substantially at right angles or radial to street right-of-way lines.
14. In case a tract is subdivided into larger parcels than normal building lots, such parcels shall be arranged so as to allow the opening of future streets and logical further subdivision.

Utilities

18. It shall be the responsibility of the Owner to provide waterlines, storm drains, sanitary sewers, bridges and street pavement to the limits of the Subdivision. These facilities shall be constructed as required for inclusion in future Town systems. Each Owner shall be responsible for the complete construction even though larger than normal sizes may be required.

Section VIII - Required Improvements

All improvements granted final approval shall be constructed in each new subdivision in accordance with the standards and requirements established by the Town Planning Board and in accordance with the condition of the final approval. The Owner may install such improvements at his own cost and expense or may secure the formation of a special district to install such improvements pursuant to pertinent laws of the State of New York.

The standards and specifications for single family residential subdivisions are contained in these regulations and design and construction standards. Additional improvements or improvements meeting more stringent standards and specifications may be required by the Planning Board for multi-family dwellings, commercial and industrial subdivisions.

Section IX - Variances and Modifications

Where the Planning Board finds that because of unusual circumstances of shape, topography or other physical features of the proposed Subdivision or because of the nature of adjacent developments, extraordinary hardship may result from strict compliance with these regulations, it may waive certain requirements of these regulations so that substantial justice may be done and the public interest secured; provided that no such waiver shall be granted which will have the effect of nullifying the intent and purpose of the Official Map, Zoning Ordinance, these regulations or ordinances of the Town. In granting changes and modifications, the Planning Board may require such conditions as will, in its judgment, secure substantially the objectives of the standards or requirements so changed or modified.

The standards and requirements of these regulations may be modified by the Planning Board in the case of a plan and program for a complete community or other planned development which in the judgment of the Planning Board provides adequate public spaces and improvements for the circulation, recreation, light, air and service needs of the community when fully developed and populated, and which also provides such covenants or other legal provisions as will assure conformity to and achievement of the plan.

Section X - Separability

A declaration of the invalidity of any provision contained in these Subdivision Regulations shall not invalidate or affect any other provision thereof.

PART II

SUBDIVISION DESIGN

AND

CONSTRUCTION STANDARDS

Section I - Introduction

These standards are issued as guides for design and construction of facilities by private developers. They are formulated so that all facilities may eventually be accepted for maintenance by the Town. With this objective, adequate design life, ease of operation and maintenance, and standardization have been given primary consideration. Each facility shall be designed and constructed as part of a future complete system.

Any standard or specification referred to shall be understood to be the current version of that standard or specification. The Board may require higher standards where it believes they are justified. The Board will also consider approval of a design or construction method which is not included in these standards.

The list of approved materials is under constant review by the Board and submission of requests for inclusion of new material is encouraged. Such requests should be substantiated by test results, specifications and other data. Listing of a material or component in the list of approved materials or approval of a new material does not prevent the Board from requiring inspections or tests deemed by the Board to be necessary before such material or component is installed.

In general, the Subdivision Plat, development map, and the plan/profiles included in the final submission shall include enough detail to show compliance with design standards. The Board may require the submission of design calculations for review by the Board's Engineer. In some cases, at the discretion of the Board, construction methods shall also be shown.

Compliance with construction standards, approved materials list and the approved Final Submission shall be required during construction. Final approval of the development construction and release of the Letter of Credit or Performance Bond shall be dependent upon such compliance. Construction methods shall conform to manufacturers' recommendations unless otherwise specified in these standards.

Section II - Design Standards

1. Surveying and Mapping

1.0 General

Procedure shall include temperature and slope corrections to distance measurements; adjustment of closed baseline traverses; presentation of all necessary data clearly and completely; and the use of proper methods to obtain the required standards of accuracy.

1.1 Surveying Accuracy

The position closure of a traverse after distribution of azimuth errors shall not

exceed 1:5,000. Discrepancies in levels between forward and backward runs shall not exceed one tenth of a foot times the square root of the length of section in miles.

1.2 Mapping Accuracy

The limits of error in any map shall not exceed 1/10 inch between points as scaled on the original map. The elevation error shall not exceed one half the contour interval.

1.3 Monuments and Bench Marks

Monuments shall be located in sufficient number to control the subdivision but as a minimum they shall be located at every point of tangency, point of curvature, point of deflection, and all intermediate points necessary to provide visibility between adjacent monuments along one right-of-way line of each street. All easements shall be similarly monumented. Iron pins shall be located at all lot corners and shall be located by reference to monuments.

Bench marks shall be set and marked with U.S.G.S. elevation unless an assumed datum is allowed by the Board. One bench mark shall be required for every 25 acres developed.

Monuments and bench marks shall be carried from existing monuments or bench marks and their origin noted on the subdivision plat. Suitable primary control points shall be shown on the plat and all other dimensions, bearings, angles and similar data shall be referred to them.

1.4 Certification

The following certification accompanied by the imprint of the New York registration seal of the land surveyor and his name shall be included on the subdivision plat; "I hereby certify this map to be substantially correct and in accordance with the accuracy required by the Town of Saratoga Subdivision Standards.

Streets

2.0 General

Streets shall follow low land whenever feasible. When a subdivision street intersects an existing street, the Board may require the Owner to improve the existing street as necessary to meet the requirements of these regulations for intersection design.

2.1 Street Width

Subdivisions shall be laid out to provide the following street and roadway widths unless otherwise shown on the Master Plan or Official Map.

<u>Street Type</u>	<u>ROW Width</u>	<u>Roadway Width</u>
Collector	60'	30'
Local & Marginal Access	60'	30'

Roadways shall be centered in the right-of-way except in unusual cases. Half streets shall be prohibited.

2.2 Street Alignment

A curve shall be required whenever a Collector or Local Street deflects more than 10°. A curve shall be required for any deflection in an Arterial street. Minimum centerline radius for horizontal curve, shall be as follows:

<u>Street Type</u>	<u>Minimum Radius</u>
Collector	300'
Local	300'
Marginal Access	150'

A tangent of at least 100 feet shall be required between reverse curves.

2.3 Street Grades

Maximum street grades shall be as follows:

<u>Street Type</u>	<u>Maximum Grade</u>
Collector	6%
Local	7%
Marginal Access	7%

Street grades shall not be less than 0.5%. Grades at street intersections shall be held to a maximum of 3% for a distance of 100 feet from the edge of pavement of the intersecting street. Vertical parabolic curves shall be introduced at changes of grade exceeding an algebraic difference of one percent and shall provide the following minimum sight distances:

<u>Street Type</u>	<u>Minimum Sight Distance</u>
Collector	250'
Local	100'
Marginal Access	100'

2.4 Street Intersections

T-intersections shall be used in residential areas where practical. Intersections of more than two streets shall be prohibited. Intersecting streets shall be laid out so as to intersect at 90° if feasible. An angle of intersection of less than 75° shall not be permitted. Any change in street alignment to meet this requirement shall be at least 100 feet from the pavement edge of the intersecting street.

Street right-of-way lines and roadways at intersections shall be rounded with a radius determined from the following table by the higher type of street in the intersection:

<u>Street type</u>	<u>Minimum R.O.W. Radius</u>	<u>Minimum Roadway Radius</u>
Arterial	Varies	Varies
Collector	25'	40'
Local	10'	25'
Marginal Access	5'	20'

The radii given are for 90° intersections and shorter radii at obtuse angles and greater radii at acute angles may be required. Intersections with arterial streets shall be held to a minimum and preferably spaced at least 1,000 feet apart.

Streets entering opposite sides of another street shall be laid out either directly opposite one another or with a minimum offset of 125 feet between their centerlines.

2.5 Dead End Streets

Dead end streets shall be provided with a turn-around at the closed end having a street right-of-way diameter of at least 140 feet and an outside edge of pavement diameter of at least 110 feet. If an island is left in the turn-around it shall be nearly level to facilitate snow plowing and there shall be no curbs around the island. The turn-around pavement shall slope to the outside of the circle. The pavement radius at the entrance to the turn-around shall be at least 50 feet for symmetrical turn-arounds and greater for offset turn-arounds. When a street is extended beyond an intersection to make provision for its future extension, a temporary turn-around shall be provided at the end of the street unless no lots are served by the extension. The temporary turn-around shall meet the requirements for a permanent turn-around.

2.6 Street Access

Access to Arterial Streets shall be restricted as far as practicable.

2.7 Street Setbacks

Setbacks from existing street shall be in accordance with the zoning law.

2.8 Fill Slopes

Where streets are constructed on new fill, the side slopes of the fill shall be as follows:

<u>Fill Height</u>	<u>Slope (Vertical and Horizontal)</u>
0-10 feet	1 to 4 or flatter
10-15 feet	1 to 3 or flatter
Higher than 15 feet	1 to 2 or flatter

2.9 Road Standards

All streets or roads offered for dedication shall be suitable and properly graded and shall meet with the approval of the Town Superintendent of Highways and the Town Engineer. Each street or road so offered for dedication shall have been compacted with suitable run of bank gravel to a depth of twelve (12) inches, size of stone not to exceed two (2) inches in diameter, extending seventeen (17) feet in each direction from the centerline of said street or road so that each street or road shall have been so constructed that the same is comprised of a road bed constructed of compacted gravel of the width of thirty-four (34) feet. No gravel shall be laid on any roadway unless the type of gravel shall have been approved by the Town Superintendent of Highways and the Town Engineer; provided, however, that the Town Superintendent of Highways and the Town Engineer may, in any case where the nature of the soil over which a street is to be laid out requires special construction, designate that the subdivider build said carriageway with a base of cinders or gravel or crushed stone and box it with run of bank gravel to a greater amount and extent than twelve (12) inches as above set forth. The road section should be constructed with no greater than a one on two slope without guide rail for fill sections. Drainage shall be taken care of by a ditch - a minimum of twenty-four (24) inches below the finished centerline.

Paving shall be plant mix asphaltic concrete applied with two (2) inches, after compaction, of a base or binder course to a width of twenty (20) feet, the center of which shall be the exact center as nearly as possible to the total 60 foot right-of-way. The second course shall be one (1) inch thick after compaction and shall be classed as "extra fine top." The outside edges of the 28 foot paved width shall again be rolled to further taper the finished pavement. The remaining 3 feet on each side of the finished pavement shall be the area designated as the contoured gutter. This area can be formed with finish material only and hand rolled. Or if preferred, dry crushed stone, size #1, can be placed thereby forming a slight gutter, and then shot with asphalt emulsion 70-B blotted by hand with size 1-A stone. The total width, gutter to gutter shall be thirty-four (34) feet. It is permissible to roll the gutter area by hand.

695 3902 / - Town Garage

3. Storm Drainage

3.0 General

In designing for storm drainage the Water Pollution Control Federation Manual of Practice on Design and Construction of Sanitary and Storm Sewers (MOP-9) shall be used as a guide. The procedures of the Manual are not binding and other good engineering practices may be accepted by the Town.

3.1 Design Criteria

All components shall be designed for runoff from the entire contributing watershed taking future development into account. In addition, the design shall be considered as part of a larger storm drainage system and shall provide drains to the limits of the subdivision.

The following criteria shall be used in designing for storm drainage:

1. Rational method shall be used for all drainage areas smaller than 100 acres. An approved method shall be used for larger area.
2. Runoff coefficient of not less than 0.35.
3. Inlet time not greater than 20 minutes from the farthest point to the first inlet.
4. Rainfall-intensity-duration-frequency curves of the U.S. Weather Bureau for the Albany area shall be used.
 - a. Five year storm for local and collector streets and residential districts.
 - b. 25 year storm for arterial highways, potentially highly developed commercial or industrial districts, and culverts carrying major streams.
5. Surface flow on streets shall be limited to a maximum of 350 feet and discharge shall be carried to a stream with bed and banks.
6. Gutter profiles may be required at intersections which involve steep grade.

3.2 Pipe

Required pipe sizes shall be determined by use of the Manning formula. Full pipe velocities shall not be less than three feet per second. Full pipe velocities greater than 10 feet per second shall be avoided whenever possible. If such velocities are unavoidable, measures shall be taken

to protect pipe from scour. The minimum size of pipe to be used shall be 12 inches. All pipe shall be installed with a minimum of two feet of cover. Pipe shall be designed for the overburden and any live loads it will be subject to. Type and class of pipe and bedding conditions shall be specified. All pipe junctions shall be in manholes or catch basins. Storm drainage shall be designed to the limits of the Subdivision and the upper end shall terminate at a catch basin or manhole.

3.3 Catch Basins and Manholes

Catch basins, manholes, frames, covers and grates shall conform to Town standards.

Storm inlets shall be located to intercept runoff before it enters an intersection and at all low points. Catch basins on storm mains shall be provided with sumps where required by the Board.

3.4 Trash Racks

Trash racks may be required where the intake of branches, or debris to the storm system may clog the line. The design of the trash rack shall be based on conditions and requirements of each particular case.

3.5 Grading

Lots shall be graded so that runoff from roofs, drives and other impervious surfaces flows toward a street except that such runoff may flow to the rear where a watercourse abuts the rear of a lot. If it is not practicable to direct runoff to the street, a grading plan for the area may be required by the Board. Such grading plan shall show that grading is designed to prevent ponding and to direct water away from all buildings.

Lots having driveways sloping away from streets shall have driveways paved so as to provide a "high-point" at or near the R.O.W. It is intended that this high point prevent street runoff from entering the lot.

4. Sanitary Sewerage

4.0 General

All components of sewage collection and disposal systems shall be designed in accordance with the following standards whichever is applicable.

1. Recommended Standards for Sewage Works adopted by Great Lakes - Upper Mississippi River Board of State Sanitary Engineers.
2. Standards for Waste Treatment Works - municipal sewerage facilities and Standards for Waste Treatment Works - Institutional and Commercial Sewerage Facilities published by the New York State Department of Environmental Conservation.

3. Sewage Disposal Systems for the Home Part III, Bulletin No. 1, published by Division of Environmental Health Services, State of New York.

4.1 Collection System

A collection system consisting of house services and mains designed for the ultimate tributary population shall be provided within the entire Subdivision. The requirement may be waived by the Planning Board if the proposed subdivision lies in an agricultural and rural residence R-R as defined in the zoning law.

4.2 House Service

A typical house service shall be shown on the plans. In cases where a house is served by an individual septic tank, the drawing shall show how the house service is to be connected to the sewer main and describe the method to be used to transfer sewage disposal from septic tank to public sewer. The method is subject to Board approval.

5. Water System

5.0 General

All components of the water system shall meet the Recommended Standards for Water Works adopted by the Great Lakes - Upper Mississippi River Board of Sanitary Engineers. Waterlines, valves and hydrants shall in addition meet the Recommended Water System Design Standards of the New York Fire Insurance Rating Organization. The design shall provide that additions to the system can be constructed without interrupting normal service or decreasing fire flows. All components shall be designed to provide present and future service as required by the Master Plan, Official Map and any water system plan adopted by the Town of Saratoga Subdivision water systems shall be connected to the Town system if feasible.

5.1 Water Supply

A source of supply shall be developed which will yield 100 gallons per resident in approximately 16 hours over a prolonged period of time without disturbing the normal ground water reserve.

5.2 Water Quality

Water supplies shall meet all requirements of the New York State Public Drinking Water Standards.

5.3 Hydro-Pneumatic Pressure System

Pumps, tanks and accessory equipment shall provide adequate pump capacity and pressure with one day storage.

5.4 Chlorination

Chlorination equipment shall be provided which will supply a minimum of eight and one-third pounds of chlorine per million gallons of water supplied.

5.5 Water Mains

Pipe and fittings shall be of approved materials and class. Class of pipe and type of material shall be specified according to ground conditions, external loading using specified bedding, and internal pressure as determined by immediate conditions and Town of Saratoga water system plans. Main sizes shall be as required by the Town in accordance with Town water system plans with no main less than 6" size. Dead end mains shall be avoided whenever feasible. When permitted, however, a blowoff or hydrant shall be installed. A six inch main loop longer than the maximum length permitted by the Recommended Water System Design Standards may be permitted provided it is temporary and final construction drawings show intersecting mains conforming to these design standards.

5.6 Valves

Valves shall be AWWA gate valves of a type approved by the Town. Valves shall be installed on every branch of an intersection, at every stub provided for future expansion and as required by the New York Fire Insurance Rating Organization, Recommended Water System Design Standards. The Owner may be allowed to omit the valve on one branch line at intersections of lines of minor importance. Valve boxes shall be installed for each valve.

5.7 Hydrants

Hydrants shall be of a type approved by the Town and shall be installed as required by the New York Fire Insurance Rating Organization's Recommended Water System Design Standards.

5.8 Services

Services shall be of approved material at least 3/4 inch inside diameter.

Section III Construction Standards

General Construction Practices

1.0 General

These construction standards shall govern all construction indicated in Final Submission of Subdivisions within the Town both on private land and on public land. Construction not covered by these standards shall be in accordance with recognized good practice such as that contained in the

State of New York's Public Works Specifications or recommendations of manufacturers' associations. All such methods not covered by these standards require approval of the Town before construction begins.

1.1 Maintenance and Protection of Traffic

The Owner shall maintain traffic and protect the public from damage to person and property while construction is being performed in any public right-of-way or any private street. Travel shall be maintained over a reasonable smooth traveled way which shall be marked as necessary for the type of street so that a person who has no knowledge of conditions can safely, and with a minimum of discomfort and inconvenience, drive or walk over all or any portion of the street. The Town shall determine whether one-way or two-way traffic shall be maintained. See paragraph 6.2 for related information concerning excavation.

1.2 Clean Up and Repair

The Owner shall clean up all debris or materials left as a result of his work and completely repair damage caused by him to any public or private property including any existing street he may have used. Resetting of surveying points and reseeding roadside areas are included in repairs required.

1.3 Restoration of Paved Street Surfaces

All utilities within street rights-of-way shall be installed before streets are paved. However, repairs or reconstruction after paving may require pavement restoration which shall be accomplished as follows:

Backfilling shall be as required for backfill within a street right-of-way. The edge of the pavement shall be cut evenly with a chisel or saw at least one foot beyond the edge of the excavation. Base material and paving equal in thickness and quality to that of the original paving shall be constructed in accordance with the standards for pavement construction. The joint between original pavement and the patch shall be sealed with a crack sealer approved by the Town.

1.4 (Reserved)

1.5 Construction Modifications in Field

The Town may require construction of a type not contemplated at the time of Final Review provided such requirements are for a higher type of construction. This is to allow for proper construction to meet conditions not known at the time of Final Review. Such construction changes shall be shown on "as built" drawings.

3. Storm Drainage System

3.0 General

The construction of storm drainage facilities shall be controlled by these standards and all other applicable Town standards.

4. Sanitary Sewerage System

4.0 General

Construction of sanitary sewerage facilities shall be controlled by these standards and all other applicable Town standards.

4.1 Maintaining Existing Service

The Owner shall maintain full service in the existing sewer system continuously. No discharge of sewage to a point outside the system shall be permitted at any time.

4.2 House Service

A "Y" branch and house service extending to the edge of the right-of-way or beyond shall be installed for each lot. A hardwood stake extending from the sewer to the ground surface shall be installed at the end of each house service before backfilling. The end of the house service shall be sealed with an approved stopper manufactured for the purpose and the stopper shall be wedged in place with stone or masonry before backfilling. The house service shall eventually be connected to the building it serves before the Town approves the building construction.

4.3 Tests

It is the intention of these construction standards to secure a system with a minimum amount of infiltration.

To check the amount of infiltration, the Town shall require infiltration-exfiltration tests.

Infiltration Tests: The Owner shall furnish and maintain a "V" notch sharp crested weir in a wood frame tightly secured in the sewer system at the locations directed by the Town. The maximum allowable infiltration shall be 200 gallons per mile, per inch of diameter of sewer main, per 24 hour day at any time. The period of testing shall be a minimum of one hour.

Exfiltration tests: The Owner shall furnish and maintain the necessary plugs, stoppers, water supply and measuring devices at locations required by the Town. All openings in the section of the system to be tested shall be securely stopped and the section filled with water to provide a minimum of two (2) feet of head over all sewers in the section.

After filling, the system shall be allowed to stand a minimum of twelve (12) hours before conducting the tests. The maximum allowable exfiltration shall be 200 gallons per mile per inch diameter of the sewer per 24 hour day at any time plus 20 gallons for each additional two (2) feet head over the basic two (2) feet minimum.

General: Any section of the sewer system that shows infiltration-exfiltration in excess of the allowable limits shall be repaired by means satisfactory to the Town. When the system has been demonstrated to be within allowable limits, the Owner shall remove all plugs, stoppers and weirs.

Sewers must be straight between manholes, and shall be tested for straightness by flashing a light from manhole to manhole, lamping, or by other suitable means.

5. Water System

5.0 General

All components shall be of approved, unused materials; manufacturers recommended procedures shall be employed.

5.1 Water Mains

The full length of each section of pipe shall rest solidly upon the pipe bed, with adequate recesses excavated for the bells and joints. The interior of all pipes shall be thoroughly cleaned of all foreign matter before being placed in the trench, and shall be kept clean during the laying operations by means of plugs or other approved methods.

The pipe shall not be laid in water or when trench conditions are unsuitable for the work, except by permission of the Engineer. Water shall be kept out of the trench until the joints have been completed. When work is not in progress, open ends of the pipes shall be securely closed so that no trench water, earth or other substances will enter the pipes or fittings.

Any section of pipe found to be defective before or after laying shall be replaced with new pipe.

Lines shall be installed with a minimum of 5' cover.

- a. Handling: Pipe and accessories shall be handled in such a manner as to insure delivery on the work site in sound, undamaged condition. Particular care shall be taken not to injure pipe coating. All surface areas of coated pipe that are damaged shall be recoated with hot bituminous material equal to that used to factory coat the pipe.
- b. Cutting: Cutting of pipe shall be done in a neat and workmanlike manner without damage to the pipe or pipe lining. Unless otherwise authorized by the Town, all pipe cutting shall be done by means of an approved type of mechanical cutter. Wheel-type cutters shall be used when practicable.
- c. Placing and Laying: Before being lowered into the trench, all sections of pipe shall be inspected for defects and tapped with a light hammer to detect cracks. Defective, damaged or unsound pipe shall be rejected.

Deflections from a straight line or grade, as required by vertical curves, horizontal curves or offsets, shall not exceed that recommended by the appropriate specifications or if not specified, then by the manufacturer's recommendations. If the alignment requires deflections in excess of these limitations, the Owner shall provide special bends or a sufficient number of shorter lengths to provide angular deflections within the limit set forth.

Before jointing, all lumps, blisters, excess coating material, oil and grease that will interfere with proper jointing shall be removed from the ends of all pipes.

- d. Mechanical Joints: Mechanical joints shall be made in accordance with the manufacturer's recommendations. Rubber gaskets shall be used. Torque wrenches, calibrated in accordance with the manufacturer's instructions, shall be used on the joint assembly.
- e. Slip-Type Joints: Slip-type joints shall be made in accordance with the manufacturer's recommendations.
- f. Anchoring: All tee connections, bends and dead ends shall be securely anchored in place by means of tie-rods and pipe clamps or concrete thrust blocks resting against undisturbed soil.

- g. Testing: After the installation of the water distribution system, or systems thereof, the water lines shall be filled and all air blown off. The system or parts thereof shall then be subjected to hydrostatic test. All testing shall be performed in the presence of the Town and shall be under the Town's supervision. Hydrostatic test and leakage allowances shall conform to Section 9903 of NBFU No. 24. If any section of the distribution system shows a leakage greater than specified, the leaks shall be located and repaired until the leakage is within the specified limits.
- h. Disinfection: Mains shall be disinfected in accordance with AWWA C601. Water containing not more than 50 parts per million of free available chlorine shall be allowed to stand in all lines and systems for at least 24 hours, after which time there shall be at least 10 parts per million residual chlorine remaining in the water. All new valves and hydrants shall be operated while the lines are filled with heavily chlorinated water. Following chlorination to the satisfaction of the Town, all disinfecting water shall be flushed from the lines until the chlorine residual does not exceed 1.0 part per million.

5.2 Valves

Valves shall be set with the stems vertical. After valves have been installed and adjusted, they shall be tested for operation under maximum operating pressure, shall be watertight and shall operate easily.

Valve boxes shall be installed so that covers are flush with the finish ground surface. Boxes shall be set vertical and centered over the valve.

A valve record card shall be completed for each valve installed. The card shall be furnished by the Town and shall be returned to the Town when completely filled out.

5.3 Hydrants

Each hydrant shall be set vertical and shall be anchored as indicated on the standard detail. Hydrants shall be set so that the distance between the finish grade line and the hose connections is between the limits indicated on the standard detail.

That portion of each hydrant below finish grade shall be given a coat of hot bituminous material prior to installation. This coating shall be equal to that used for coating of cast iron fittings and water lines.

A hydrant record card shall be completed for each hydrant installed. The card shall be furnished by the Town and shall be returned to the Town when completely filled out.

5.4 Services

All service taps shall be made with a service clamp installed unless factory installed. The corporation stop shall be inserted as recommended by the manufacturer for the type pipe installed.

The service shall be installed in accordance with backfilling requirements of these standards and in accordance with standard details.

6. Pipeline Construction

6.0 General

All labor, materials, equipment, tools and services required for the furnishing and installation of any type of pipe shall conform to the following specifications.

6.1 Pipe

All pipe shall be installed in the sizes and to the lines and grades shown on the approved subdivision drawing. The type and specifications of pipe to be furnished and installed in each location shall be as designated on the subdivision drawings. Pipe shall be new number one pipe and shall be rejected if found not to meet the minimum requirements set by the Town.

All pipe lines and appurtenances of whatever type or description shall be constructed in an approved manner to the complete satisfaction of the Town.

Where lift holes are provided in concrete pipe they shall be filled with a stiff mortar mix after the pipe is installed in the trench.

The Owner, at his own expense, at all times during the progress of the work, shall keep the trenches and excavations free from water. Water from trenches and excavations shall be disposed of in such a manner as will neither cause injury to the public health, nor to the surface of streets, nor cause any interference with the use of public rights-of-way. Water shall not be allowed to flow away through newly laid sewers.

All pipe shall be installed to the limits of the approved subdivision section and shall terminate in a manhole, catch basin, hydrant or blowoff as appropriate. Stubs shall be installed in manholes and catch basins to provide for future extension of pipe lines.

6.2 Excavation General

Necessary arrangements shall be made by the Owner with all persons, firms, or corporations owning or using any poles pipes, tracks, or conduits, etc. affected by his construction to maintain and protect such facilities during construction. In the event any existing gas pipes, water pipes, conduits, sewers, tile drains or poles are blocked or interfered with by the

excavation required on this project, the Owner shall maintain them in continuous operation and restore them to the same condition as they were prior to the start of construction.

Sidewalks and pavements must in no case be blocked or obstructed by excavated material except with the approval of the Town and then only when adequate provisions have been made for a satisfactory temporary passage of pedestrians and vehicles. Adequate bridging and planked crossings must be provided and maintained across all open trenches for pedestrians and vehicles when so ordered by the Town. Barriers, lights, flares and watchmen shall be provided and maintained by the Owner at all trenches, excavations and embankments as required by the Town.

The excavation of the trench shall not advance more than 200 feet ahead of the completed masonry or pipe work except where necessary to drain wet ground. The width of trenches in which pipe is to be installed shall be such as to provide adequate space for workmen to place and joint the pipe properly and shall be in accordance with the following:

Maximum Trench Widths One (1) Foot Above Top of Pipe

<u>Pipe Size</u>	<u>Trench Width</u>
8" to 12"	30"
15" to 18"	O.D. + 16"
21" to 27"	O.D. + 18"
30" to 36"	O.D. + 24"

Note: O.D. is outside diameter of pipe barrel.

The Owner shall furnish, put in place and maintain such sheeting and bracing as may be required to support properly the sides and ends of excavations, and to prevent injury to the structure built or to persons or property.

If at any time the Town so orders, the Owner shall install such additional sheeting and bracing as may be required by the State of New York, Department of Labor, by adverse soil conditions, or by the Town; but compliance with such orders or failure on the part of the Town to exercise its right to give such order shall in no way release the Owner from liability for damage caused by weak or insufficient sheeting nor from his responsibility to protect the work and adjacent property. Voids appearing outside the sheeting shall be immediately and compactly filled with suitable material and to the satisfaction of the Town.

All sheeting and bracing shall be in accordance with the Industrial Code Rule No. 23 of the State of New York, Department of Labor, Board of Standards and Appeals.

Trench bottoms shall be excavated to conform to the type of bedding specified for the project.

Where excavations are opened and, in the opinion of the Town, the materials in place are not adequate for structural stability of the completed work, the Town may order the Owner to carry the excavation to an additional depth, furnish and place concrete cradles, sand or gravel refill and/or timber and piling foundations.

6.3 Rock Excavation

Excavation and trenches in rock shall be carried to a depth of one-fourth the diameter of the pipe but in no case less than 6 inches below the pipe bottom, and shall be made by any acceptable method, including use of explosives.

Where blasting is necessary, it shall be done by men experienced in such work. All blasts shall be well covered; and provisions made to protect pipes, conduits, sewers, structures, persons and property adjacent to the site of the work. Prior to blast, all persons in the vicinity shall be given ample warning. Blasting will not be permitted between the hours of 6:30 p.m. and 6:30 a.m., except with special permission, nor within twenty-five (25) feet of the completed work.

All handling and use of explosives shall be in accordance with Industrial Code Rules No. 23 and 39 of the New York Department of Labor, Board of Standards and Appeals and Article 16 of the New York State Labor Law.

The Owner shall secure all permits required by law for blasting operations and any additional hazard insurance required.

6.4 Lines and Grades

Three batter boards, a top line plumb bob and grade pole shall be used to transfer line and grade from grade stakes to pipe line unless some other method of checking the pipe invert grade and line is approved by the Town.

6.5 Bedding

The class of bedding to be used shall be as specified in the final submission drawings. There shall be excavation for bells and flanges in all classes of bedding. Beddings for pipe shall conform to one or more of the following:

a. First Class Bedding

First Class Bedding is that method of laying pipe in which the pipe is carefully bedded in compacted granular materials placed on a flat trench bottom. The granular material shall be crushed stone, pea gravel or sand and maximum particle size shall be 3/4". The depth of the granular bedding below the bottom of the pipe shall be one-fourth the outside pipe diameter or 4 inches, whichever is greater and shall extend to a point 4 inches over the top of the pipe. If mechanically tamped, material may be placed in 6" layers; 3" layers if tamped by hand. If a clean, dry, free-flowing sand is used, no compaction will be required. All materials up to 12" over the top of the pipe shall be placed by hand.

b. Concrete Cradle Bedding

Concrete Cradle Bedding is that method of bedding pipe in which the lower part of the pipe exterior is bedded in plain or reinforced concrete of 2,500 p.s.i. or greater, having a minimum thickness under the pipe of one-fourth the nominal inside diameter and extending up the sides of the pipe for a height equal to one-fourth of the outside diameter.

The cradle shall have a width at least equal to the outside diameter of the barrel of the pipe plus 8 inches and it shall be constructed monolithically without horizontal construction joints. The remainder of the bedding to a point four (4) inches over the top of the pipe shall conform to "First Class Bedding".

c. Concrete Encasement

Concrete Encasement is that method of bedding pipe in which the entire pipe is jacketed by plain or reinforced concrete having a compressive strength of 2,500 p.s.i. or greater. The encasement width and height shall be at least equal to the outside diameter of the barrel of the pipe plus 8 inches, or as shown on the approved subdivision drawings.

Normally stronger pipe should be used with concrete cradle or encasement being permitted only in unusual cases.

6.6 Pipe Laying

Pipe shall be protected during handling against impact shocks and free fall. Pipe shall be kept clean at all times.

The laying of pipe in prepared trenches shall be commenced at the lowest point with the spigot ends pointing in the direction of flow.

All pipe shall be laid with ends abutting and true to line and grade. They shall be carefully centered, so that when laid they will form a uniform invert.

Preparatory to making pipe joints all surfaces of the portions of the pipe to be jointed or of the factory made jointing material shall be clean and dry. Lubricants, primers, adhesives, etc. shall be used as recommended by the pipe or joint manufacturer. The jointing of materials or factory fabricated joints shall then be placed, fitted, joined and adjusted in such a workmanlike manner as to obtain the degree of watertightness required.

Trenches shall be kept water-free and as dry as possible during bedding, laying and jointing and for as long a period as required. As soon as possible after the joint is made, sufficient backfill material shall be placed along each side of the pipe to offset conditions that might tend to move the pipe off line and grade.

All ends of pipe runs shall be capped with standard stoppers or with a fitting provided with an approved joint. If stoppers are used they must be wedged in place with boulders or masonry blocks. Large lines may be bricked off at the ends or otherwise sealed in a manner approved by the Engineer.

6.7 Backfilling

All backfilling to a point four (4) inches over the top of the newly laid pipe shall be as specified under "Bedding". To a point 18" over the top of the pipe there shall be no stones larger than two (2) inches.

No frozen material shall be used for backfill.

When backfilling in open-cut across or within the right-of-way limits of any street, road, highway or railroad, the remainder of the backfill shall be select granular material. Compaction for the entire depth shall be as directed under paragraph 6.5 "Bedding" or with water if satisfactory drainage is provided for free water.

When backfilling in unpaved areas outside the rights-of-way, the excavated material may be used to complete the backfilling, provided all deleterious contents, if any, are removed as directed by the Town. The backfill shall be rounded off over the trench not higher than eight (8) inches. Material shall be compacted in layers not more than two (2) feet thick by hand or by machine.

No pipe shall be covered before permission is given by the Town.

Under no circumstances shall water be permitted to rise in trenches before they are backfilled.

Backfilling shall be completed to a point two (2) feet above the top of all pipe laid each day. Operations shall be scheduled so that the trench is completely backfilled to within two hundred (200) feet of the end of the completed, installed sewer at the end of each day.

Whenever timber sheeting is driven to a depth below the elevation of the top of the pipe, that portion of the sheeting below the elevation of the top of the pipe shall not be disturbed or removed. Whenever timber sheeting is driven for the protection of trench walls in water-bearing soil, no portion of such sheeting below a level four (4) feet over the top of the pipe shall be removed.

6.8 Tunnels

Methods of excavation support and backfill in tunnels made beneath existing structures, railroads, pavements and sidewalks for the installation of pipe or conduits, shall be subject to approval of the Town before work is begun.

6.9 Jacking and Boring

Methods of jacking or boring to install pipe shall be approved by the Town before such work is started.

6.10 Manholes and Catch Basins

Materials shall be approved by the Town. Concrete block masonry shall be constructed in horizontal courses with vertical joints staggered.

Brick masonry shall be constructed in horizontal courses, with a header course every seventh course.

Concrete block and brick sidewalls shall be laid in a full bed of mortar. Joints on interior walls shall be struck smooth. All joints in block and brick shall be completely filled.

Concrete block and brick manholes shall be plastered with a mortar coat one-half ($\frac{1}{2}$) inch thick on the outside.

Precast concrete rings shall be laid with full mortar joints.

Mortar shall consist of one part Portland Cement and two parts clean torpedo sand with 10% hydrated lime added.

Pipe placed through manhole or catch basin sidewalls, and stubs installed for future extensions shall extend through the walls a sufficient distance to allow connection on the outside. Such pipes shall be struck smooth on the inside in line with the inside wall of the manhole. The manhole masonry shall be carefully constructed around all pipes, so as to prevent leakage along the outer surfaces.

Frame castings shall be set in full mortar beds on top of masonry.

The top four (4) to twelve (12) inches of the manhole, directly under the casting shall be constructed of brick to provide for adjustment to grade and future construction. Field cutting of precast manhole sections shall not be allowed for grade adjustment.

6.11 Connections

Connections of new lines to existing lines when encountered in construction and not shown on the subdivision drawings shall be made where ordered by the Town. Such connections shall be made within a manhole or catch basin in the case of sewers or storm drains except for house sewer and drain connections.

Junctions for future sewer connections indicated on the final subdivision drawings shall be sealed as specified in paragraph 6.6 Pipe Laying.

7. Plain and Reinforced Concrete

7.0 General

Concrete used in any type of construction shall meet the strength and durability requirements of these standards as determined by testing procedures specified herein. Materials used shall meet the requirements of these standards and shall be approved by the Board for the intended use.

7.1 Materials

- a. Cement: Cement shall be one of the types approved by the Board and the type selected shall be the proper one for its intended use.
- b. Aggregate: Aggregates shall be approved by the Board. Aggregates failing to meet these requirements but producing concrete of the required quality as shown by special tests or actual service may be used with the permission of the Board.

The maximum size of the aggregate shall be one-fifth of the narrowest dimension between sides of the forms within which the concrete is to be cast, and three-fourths of the minimum clear spacing between reinforcing bars, or between forms and reinforcing bars. For unreinforced slabs, the maximum size of aggregate shall be one-third the slab thickness.

- c. Mixing Water: Water used in mixing concrete shall be clean and free from injurious amounts of oils, acid, alkalies, organic materials, salts or other substances that may be deleterious to concrete or steel.

7.2 Quality of Concrete

- a. Class of Concrete: Concrete installed in various structures or units shall be one of the three classes defined in the following paragraphs. The class to be installed shall be as specified in the Subdivision Final Approval.

Class of Concrete

Class I	4000	psi	@	28 days
Class II	3000	psi	@	28 days
Class III	2500	psi	@	28 days

- b. Water Cement Ratio: All concrete shall be proportioned on the basis of water-cement ratio which is defined as the ratio of the total quantity of water in the mixture, including the surface water carried by the aggregate, to the quantity of cement. The ratio is expressed in U.S. gallons, 8 1/3 pounds to the gallon, per 94 pound sack of cement.

Concrete that is subject to freezing temperatures while wet shall have a water-cement ratio not exceeding 6 gallons per bag and shall contain entrained air.

- c. Concrete Proportions and Consistency: The proportions of the concrete shall produce a mixture that will work readily, with the placement method used, into the corners and angles of the forms and around reinforcement. Neither segregation of materials in the mixture nor the collection of excess free water on the surface shall be permitted.

The slump of concrete shall be the minimum that is practicable. When vibrators are used to consolidate the concrete, the slump shall not exceed four (4) inches, otherwise the slump shall not exceed (6) inches.

The methods of measuring the concrete materials shall be such that the proportions can be accurately controlled and easily checked. Measurement of materials for ready-mixed concrete shall conform to Specifications for Ready-Mixed Concrete (ASTM C94).

7.3 Tests on Concrete

- a. Sampling: As the work progresses, concrete shall be sampled in accordance with ASTM method of sampling fresh concrete (ASTM C172).
- b. Slump Test: Slump tests shall be made according to ASTM Method of Test for Slump of Portland Cement Concrete (ASTM C143).
- c. Compression Test: Compression test specimens shall be made and cured according to ASTM Method of Making and Curing Concrete Compression and Flexure Test Specimens in the field (ASTM C31). Not less than three specimens shall be made for each test at each age nor less than one test for each 150 cu. yd. of concrete of each class. At least one test per day shall be made of each class of concrete used that day.

Specimens shall be taken by the Owner or his representative under the direction of the Town and the tests made by a laboratory approved by the Town. The cost of transportation to the laboratory and of testing the concrete cylinders shall be borne by the Owner. The Owner shall furnish 2 copies of all test results to the Town.

Additional specimens cured under job conditions may be required when, in the opinion of the Town, there is a possibility of the surrounding air temperature falling below 40°F or rising above 90°F.

Specimens shall be tested according to ASTM Method of Test for Compressive Strength of Molded Concrete Cylinders (ASTM C39).

The standard age of test specimens shall be 28 days, but 7 day specimens may be used, provided that the relationship between the 7 and 28 day strengths of the concrete is established by test for the materials and proportions used.

If after testing, the average strength of test cylinders is found to be more than 10 percent below the required strength the Town may elect either to permit such concrete to remain in place and require the Owner to forfeit from his performance bond an amount agreeable to both the Owner and the Town or require the Owner at his own expense, to remove the concrete area deficient in the specified strength and replace it with concrete of satisfactory quality.

7.4 Mixing and Placing Concrete

- a. Preparation of Equipment and Place of Deposit: Before placement, all equipment for mixing and transporting the concrete shall be cleaned and all debris and ice shall be removed from the places to be occupied by the concrete. Forms and subbase shall be thoroughly wetted (except in freezing weather) or oiled. The reinforcement shall be thoroughly cleaned of ice, dirt, rust, scale or other coatings.

Standing water shall be removed from place of deposit before concrete is placed unless otherwise permitted by the Town. All laitance and other unsound materials shall be removed from hardened concrete before additional concrete is added.

- b. Mixing of Concrete: For job-mixed concrete, the mixer shall be rotated at a speed recommended by the manufacturer. Each batch of 1(one) cu. yd. or less shall be mixed for at least 1 (one) minute after all materials are in the mixer. The mixing time shall be increased 15 seconds for each additional cubic yard or part thereof. The entire batch shall be discharged before the mixer is recharged.

Ready-mixed concrete shall be mixed and delivered in accordance with Specifications for Ready-Mixed Concrete (ASTM C94).

- c. Conveying of Concrete: Concrete shall be conveyed from the mixer to the place of final deposit by methods that will prevent separation or loss of Materials.

Equipment for chuting, pumping and pneumatically conveying concrete shall be of such size and design as to achieve a practically continuous flow of concrete at the delivery end without separation of materials.

- d. Placing of Concrete: Concrete shall be deposited as nearly as practicable in its final position to avoid segregation due to rehandling or flowing. The placing of concrete shall be carried on at such rate that concrete is at all times plastic and flows readily into the spaces between the bars. No concrete that has partially hardened or been contaminated by foreign material shall be deposited on the work, nor shall retempered concrete be used.

All concrete shall be thoroughly consolidated by suitable means during placement. It shall be thoroughly worked around reinforcement and embedded fixtures and into the corners of the forms. Tools used shall be such that they will not cause segregation of aggregates.

- e. Curing of Concrete: Provision shall be made for maintaining concrete in a moist condition for a period of at least 5 (five) days after placement. For high-early-strength concretes, however, moist curing shall be provided for at least the first 2(two) days, when concrete and air temperatures are above 50 deg. F.; longer periods of curing shall be required when temperatures are below 50 deg. F.
- f. Cold Weather Concreting: Adequate equipment shall be provided for heating concrete materials and protecting concrete during freezing or near-freezing weather. No frozen materials or materials containing snow or ice shall be used in the concrete.

All reinforcement, forms, fillers and ground with which the concrete is to come in contact shall be free from snow and ice. Whenever the temperature of the surrounding air is below 40 deg. F. all concrete placed in the forms shall have a temperature of 45 deg. F. or higher after placement.

Adequate means shall be provided for maintaining this temperature for 4 (four) days. When high-early-strength concrete is used, a temperature of 45 deg. F. shall be maintained for 3 (three) days. In either case, any additional time necessary to ensure proper curing of the concrete shall be provided as directed by the Town.

The housing, covering, or other protection used in connection with curing shall remain in place and intact at least 24 hours after the artificial heating is discontinued. No dependence shall be placed on salt or other chemicals for the prevention of freezing.

- g. Hot Weather Concreting: In hot weather, suitable precautions shall be taken to avoid drying of the concrete prior to finishing operations. Use of windbreaks, sunshades, fog sprays, or other devices shall be provided as directed by the Town.

Concrete deposited in hot weather shall not have a placing temperature that will cause difficulty from loss of slump, flash set or cold joints. Concrete temperatures shall be less than 90 deg. F.

- h. Forms: Forms shall conform to shapes, lines and dimensions of the members as called for in the Subdivision Final Submission and shall be sufficiently tight to prevent leakage of mortar. They shall be properly braced or tied together so as to maintain position and shape.

Forms shall be removed in such a manner as to ensure the complete safety of the structure. Where the structure is supported on shores, the removable floor forms, beams and girder sides and column and similar vertical forms may be removed after 24 hours provided the concrete is sufficiently hard. In no case shall the supporting forms or shoring be removed until members have acquired sufficient strength to support their weight and imposed loads safely.

- i. Placing and Splicing of Reinforcements: The reinforcements shall be protected by the thickness of the concrete indicated in the Subdivision Final Approval. Where not otherwise shown, the thickness of concrete over the reinforcement shall be as follows:

- (i) Where concrete is deposited against the ground without the use of forms - not less than 3 inches.
- (ii) Where concrete is exposed to the weather or to the ground but placed in forms - not less than 2 inches for bars larger than No. 5 and 1½ inches for No. 5 bars or smaller.
- (iii) In slabs and walls not exposed to the ground or to the weather - not less than ¾ inches.
- (iv) In beams, girders and columns not exposed to the ground or to the weather - not less than 1½ inches.
- (v) In all cases - at least equal to the diameter of bars or 1½ times the side dimension of a square bar.

8. Cable and Conduit

8.0 General

Underground cable for telephone and/or electric service shall be installed in conformance with requirements listed herein and other sound installation practices.

8.1 Sequence of Construction

Installation of cable and conduit shall be subsequent to R.O.W. grading but prior to any paving operations. Grading shall be within 6" of proposed final grade.

8.2 Conduit

Rigid conduit shall be placed under all roadways prior to the installation of the cable. Conduit of appropriate size shall conform to the "National Electric Code". Conduit installation to conform to excavation and backfilling items under Item 5T, N.Y.S.D.P.W. Specifications with the sand backfill to be at least 6" below and 6" above the conduit.

8.3 Identification

To protect from inadvertent cuts into any cable any buried cable shall have placed approximately one foot above such cable a continuous ribbon of brightly colored, non-reactive plastic.

8.4 Documentation

The developer shall indicate all cable and conduit locations on the "as built" drawings when submitted to the Town.

PART III

SUBDIVISION STANDARD DRAWINGS

SUBDIVISION
STANDARD DRAWINGS

<u>Dwg. No.</u>	
1.1	Standard Mapping and Construction Symbols
1.2	Standard Monument
1.3	Street Name Signs
2.1	Typical Sections for Roadway
3.1	Typical Catch Basin Grate
3.2	Typical Catch Basin Frame
3.3	Typical Catch Basins
4.1	Typical Sanitary Manhole Showing Drop Feature
4.2	Typical Manhole Frame and Cover
5.1	Waterline Blowoff
5.2	Hydrant Installation
5.3	Typical House Water Service

FEATURE	SYMBOL	FEATURE	SYMBOL
Paved Road		Water Elev.	W.E. 105.6
Dirt Road		Bldg. in General	
Curb		Building to be Demolished	
Cement Concrete		Cemeteries	
Asph. Concrete		County Bound.	SARATOGA SCHENECTADY
Original Ground		Town Bound.	CLIFTON PARK HALFMOON
Rock		Prop. Line	
Bridge		R.O.W. Line	
Highway Underpass		Street Name Sign	
Culvert		Fire Hydrant	
Catch Basin		Gas Line	
Ditch		Electric Line	
Stream		Telephone Line	
Lake and Pond		Water Line	
Marsh		Water Valve	
Contours		Sanitary Sewer	
Depression		Storm Drain	
Rock Outcrop		Manhole	Letter Shows Type
Spot Elevation	X 103.4	Soil Drill Hole	Ident. by No.
Bench Mark	X BH 131 USGS EI. 241.31	Soil Auger Hole	Ident. by No.
Triangulation Station	△ N 938, 122.10 NYS E 590, 690.60	Soil Probe Hole	Ident. by No.
North Arrow True		Soil Test Pit	Ident. by No.
North Arrow Magnetic		Percolation Test	Ident. by No.
Single Track R.R.		TOWN OF SARATOGA SUBDIVISION STANDARD DWG. 1.1 STANDARD MAPPING AND CONSTRUCTION SYMBOLS	
Multiple R.R. Track			
Abandoned Track			
Monument			

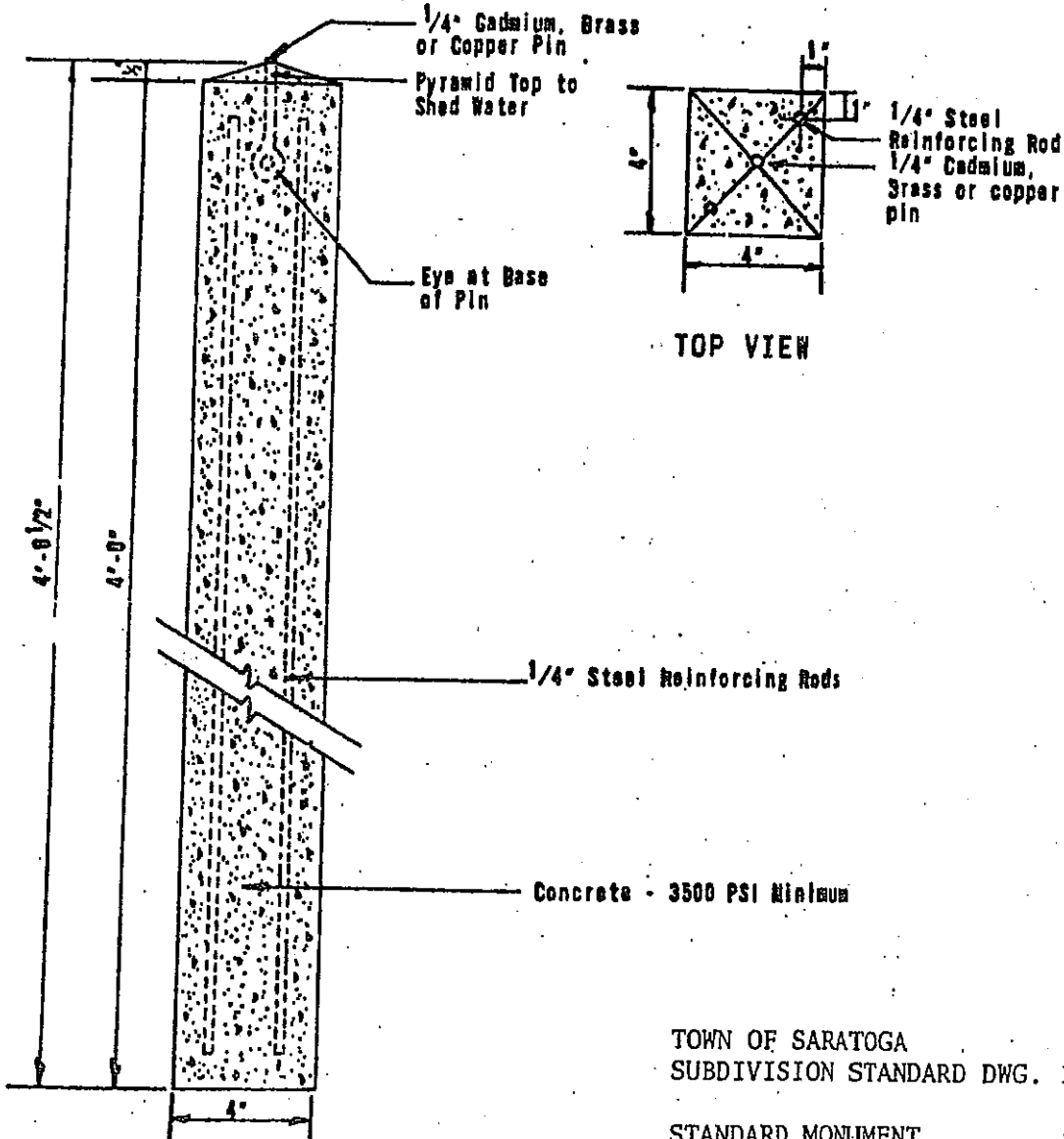

TOWN OF SARATOGA
 SUBDIVISION STANDARD DWG. 1.2
 STANDARD MONUMENT

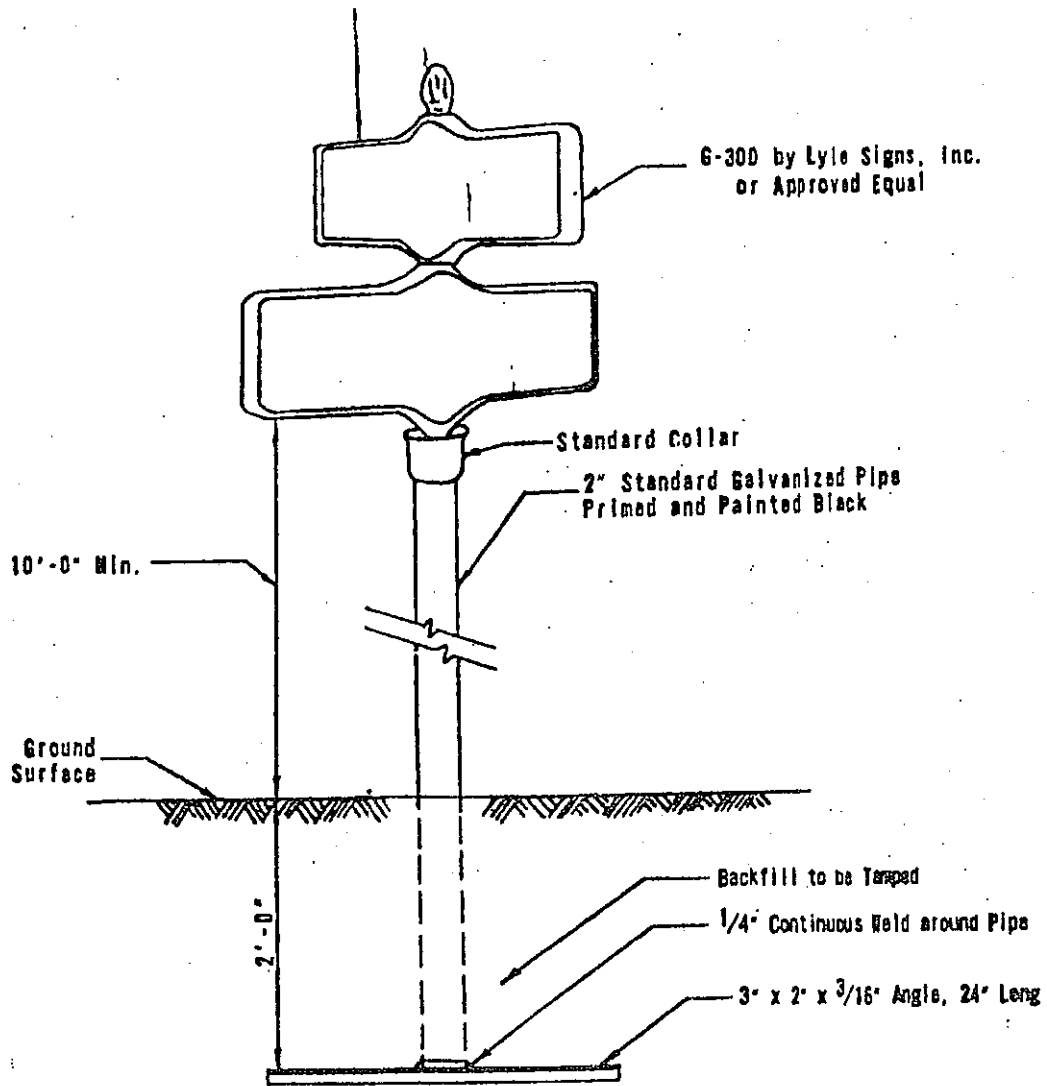

TOWN OF SARATOGA
 SUBDIVISION STANDARD DWG. 1.3

STREET NAME SIGN

TOWN HIGHWAYS TYPICAL SECTIONS for NEW ROADS TOWN of SARATOGA

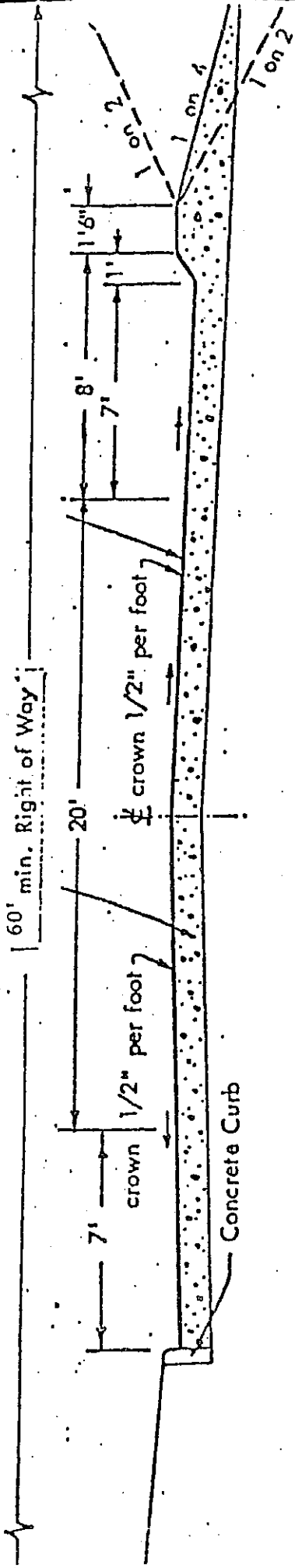

Refer to Road Standards on page 4a of SUBDIVISION DESIGN AND CONSTRUCTION STANDARDS

Scale 1" = 50'

Amended 6/87

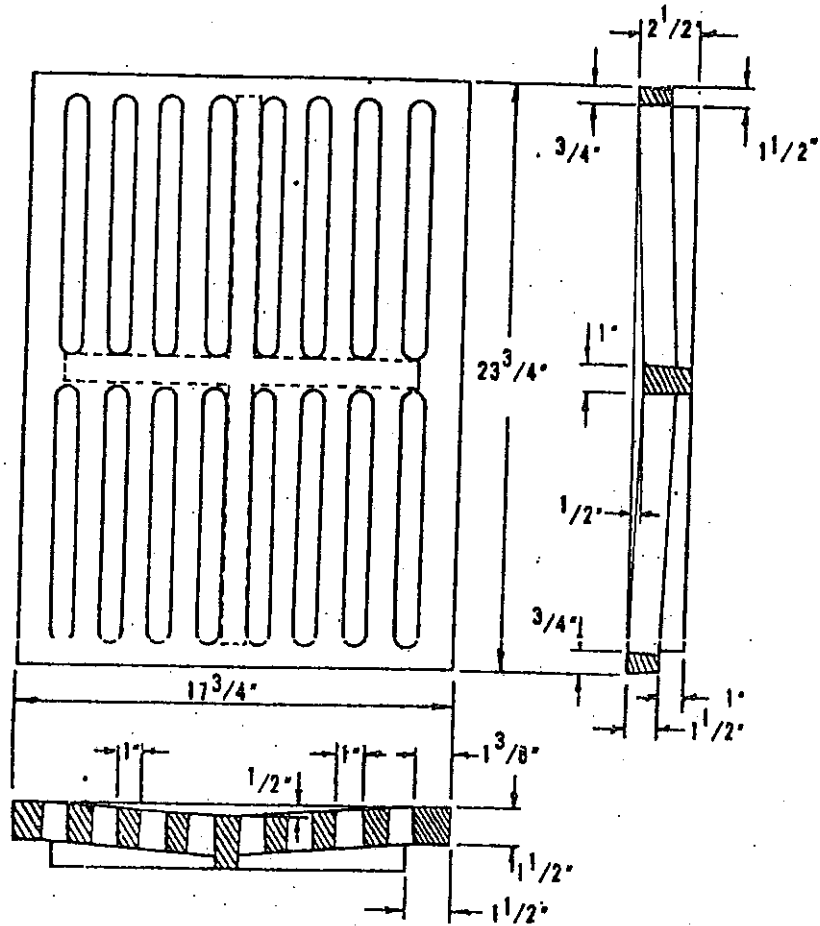

NOTES
 GRATE - 95#
 SPECIFICATION - N.Y. STATE
 D. P. W. MB

TOWN OF SARATOGA
 SUBDIVISION STANDARD DWG. 3.1

TYPICAL CATCH BASIN GRATE

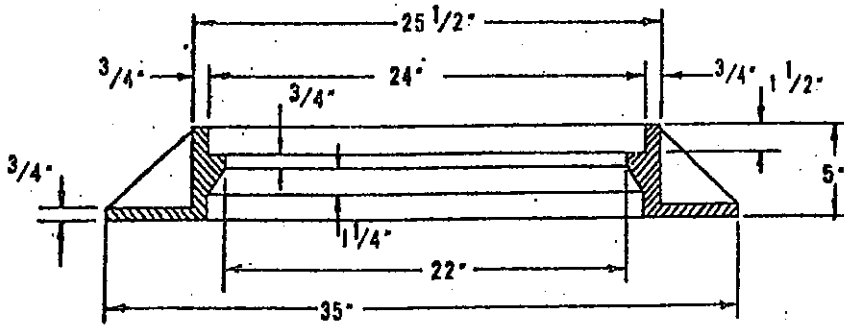
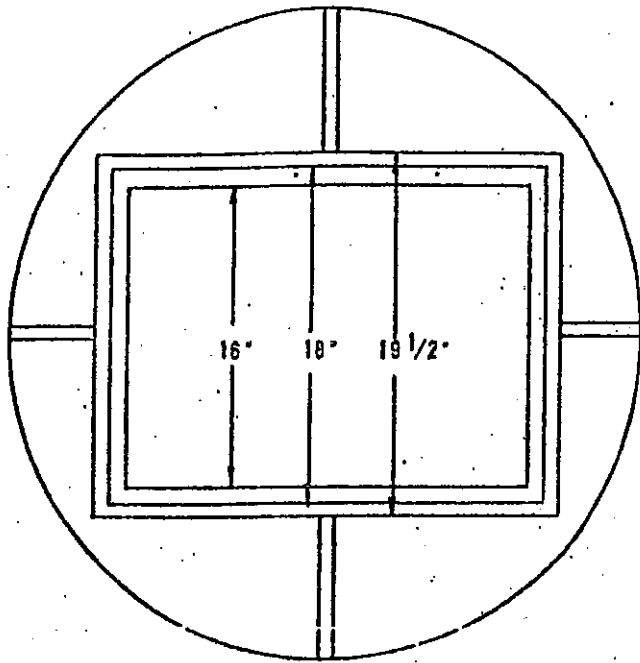

NOTES:
 FRAME 281#
 SPECIFICATION N.Y. STATE
 D.P.W. MB

TOWN OF SARATOGA
 SUBDIVISION STANDARD DWG. 3.2

TYPICAL CATCH BASIN FRAME

**TYPE A CATCH BASIN
WITHOUT SUMP FOR
BRANCH DRAINS OR
STEEP SLOPES**

**TYPE B CATCH BASIN
WITH SUMP FOR MAIN
DRAIN WITH
SHALLOW SLOPES**

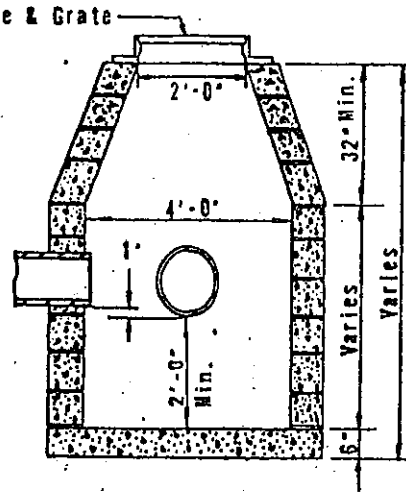
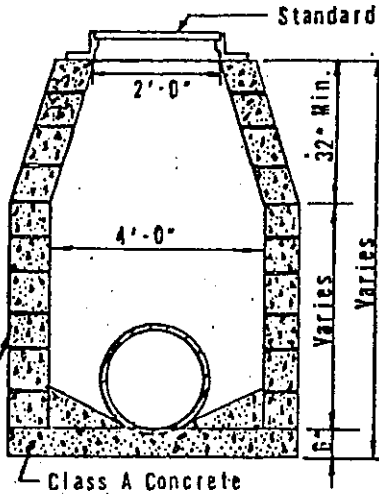

SECTION A-A
8" x 8" Conc. Manhole Blocks, Brick,
or Precast Manhole Sections

SECTION B-B

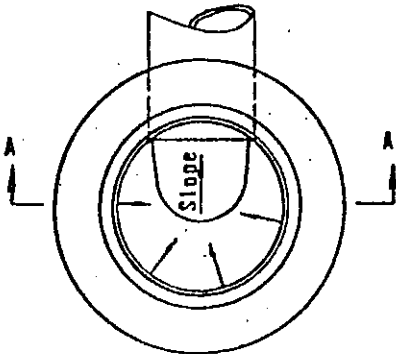

PLAN

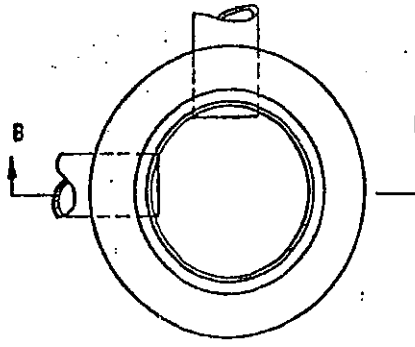

PLAN

TOWN OF SARATOGA
SUBDIVISION STANDARD DWG. 3.3

TYPICAL CATCH BASINS

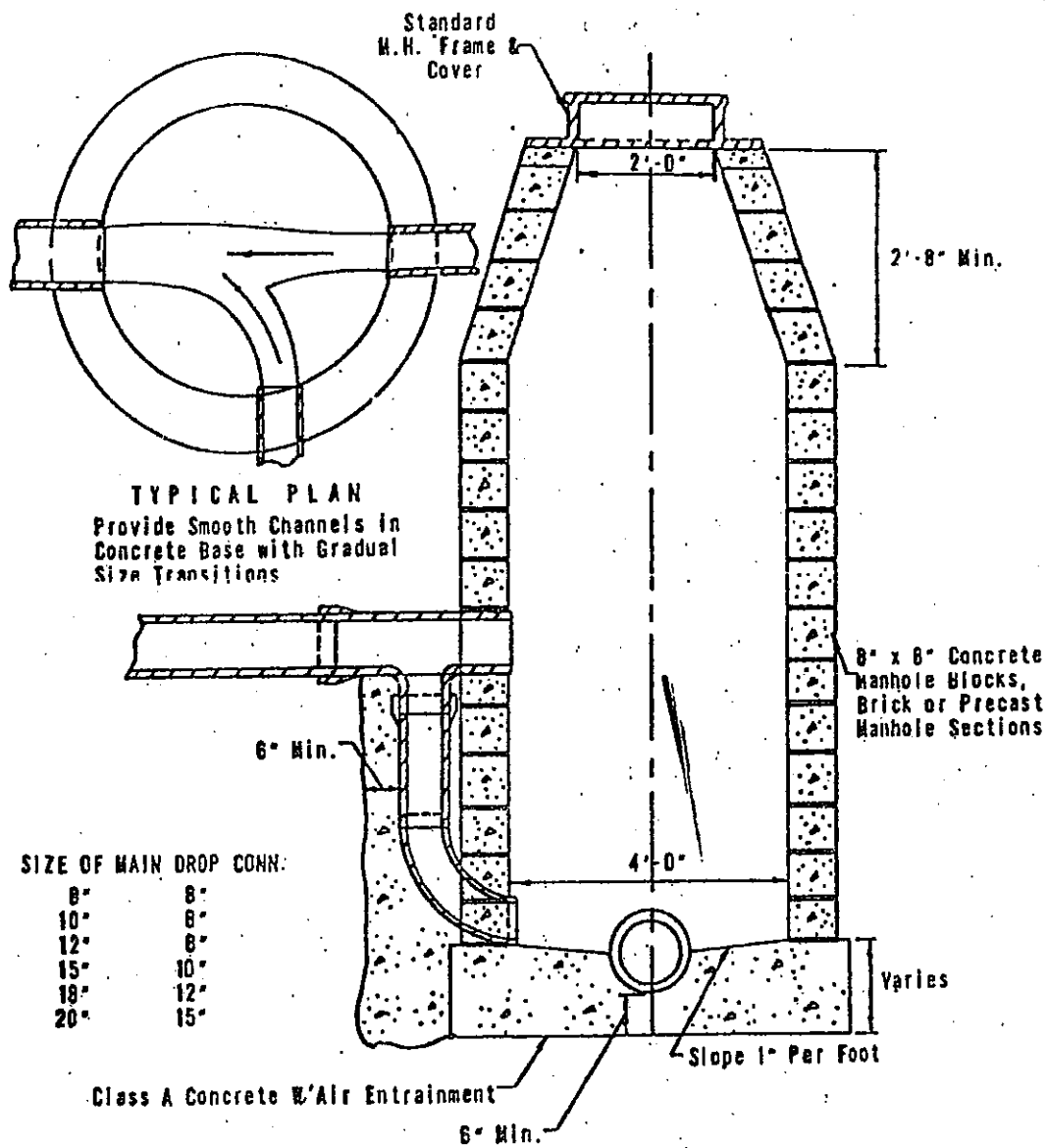

TOWN OF SARATOGA
SUBDIVISION STANDARD DWG. 4.1

TYPICAL SANITARY MANHOLE
SHOWING DROP FEATURE

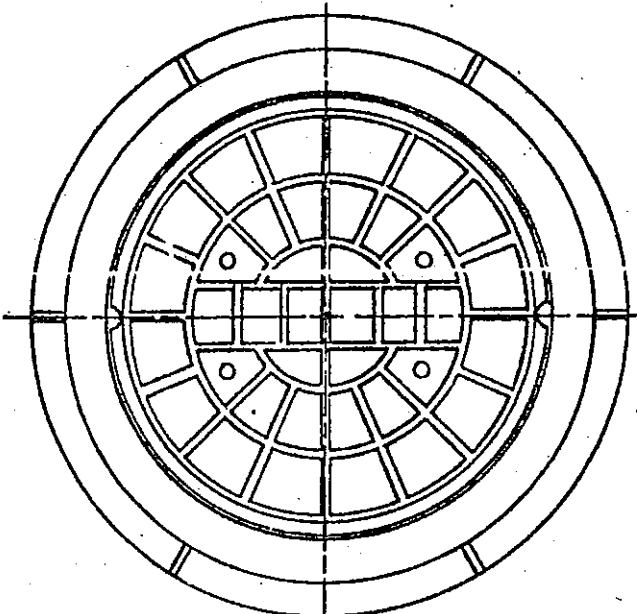
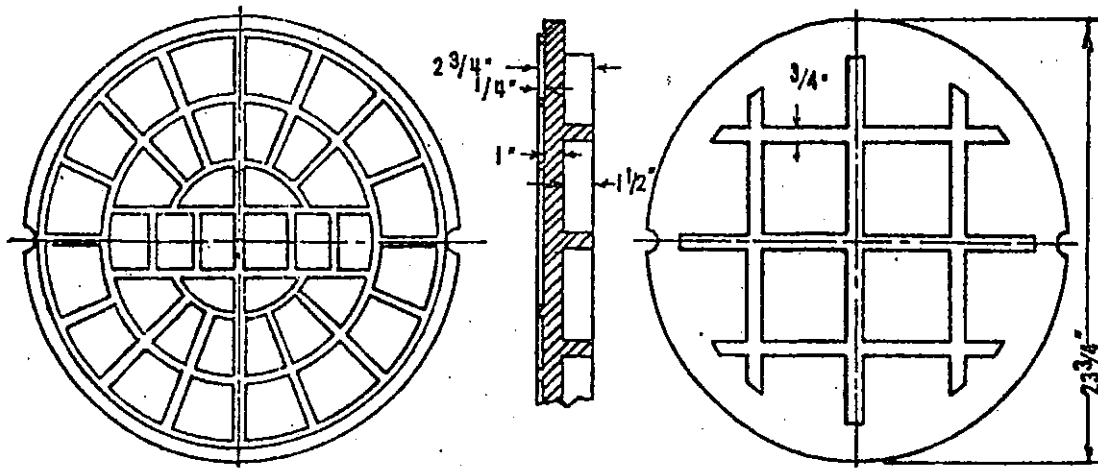

NOTES
 COVER - 150#
 FRAME - 255#
 SPECIFICATION - N.Y. STATE
 D. P. W. MB

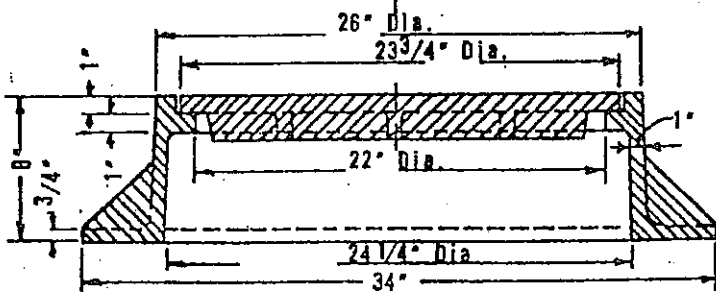

TOWN OF SARATOGA
 SUBDIVISION STANDARD DWG. 4.2
 TYPICAL MANHOLE FRAME & COVER

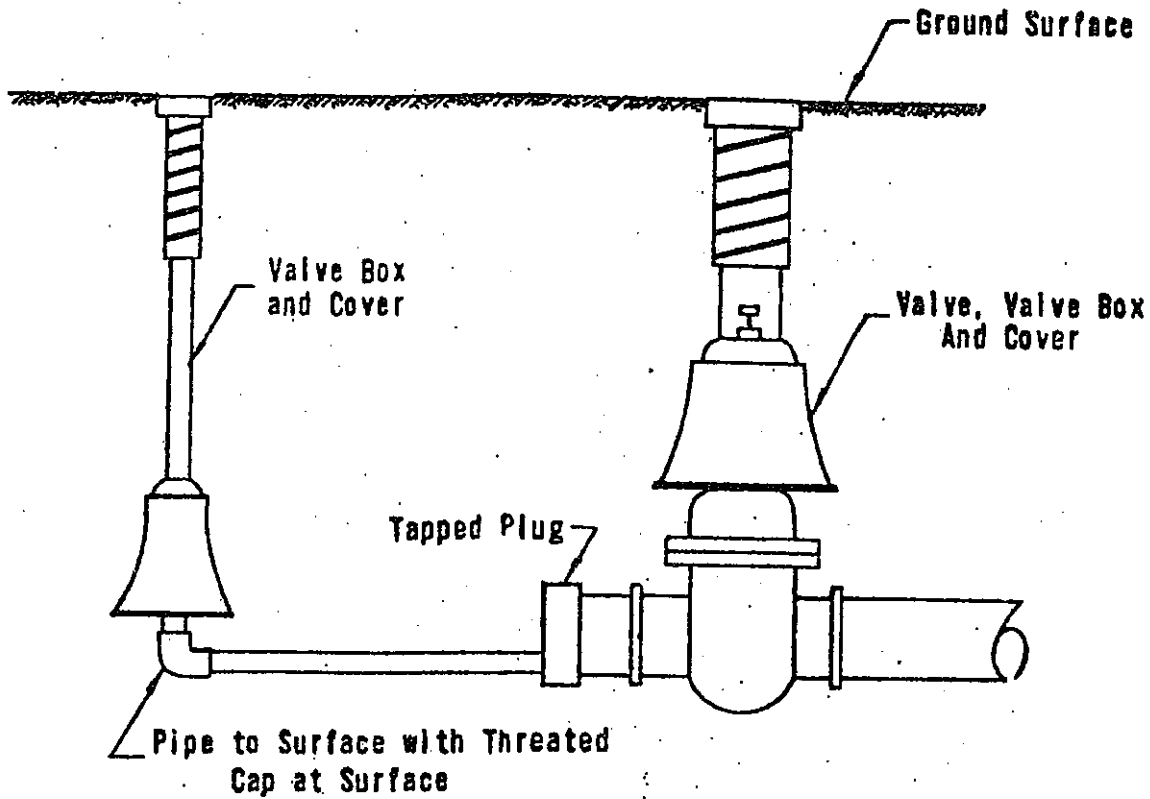

Not to Scale

MAIN SIZE	BLOWOFF SIZE
6"	1 1/2"
8"	2"
10"	2 1/2"
12"	3"
14", 16"	4"
18", 20"	6"

TOWN OF SARATOGA
 SUBDIVISION STANDARD DWG. 5.1

WATERLINE BLOWOFF

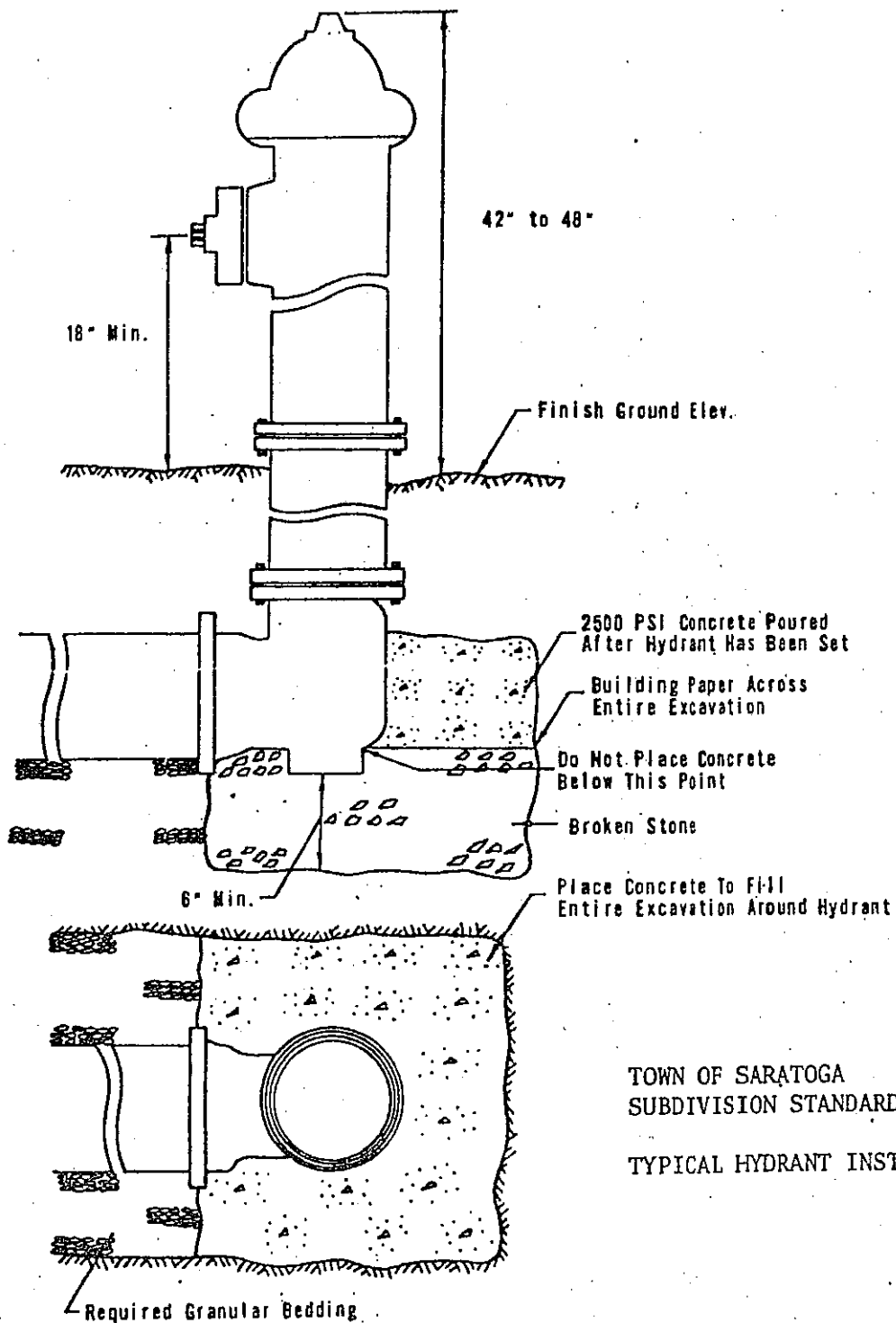

TOWN OF SARATOGA
 SUBDIVISION STANDARD DWG. 5:2

TYPICAL HYDRANT INSTALLATION

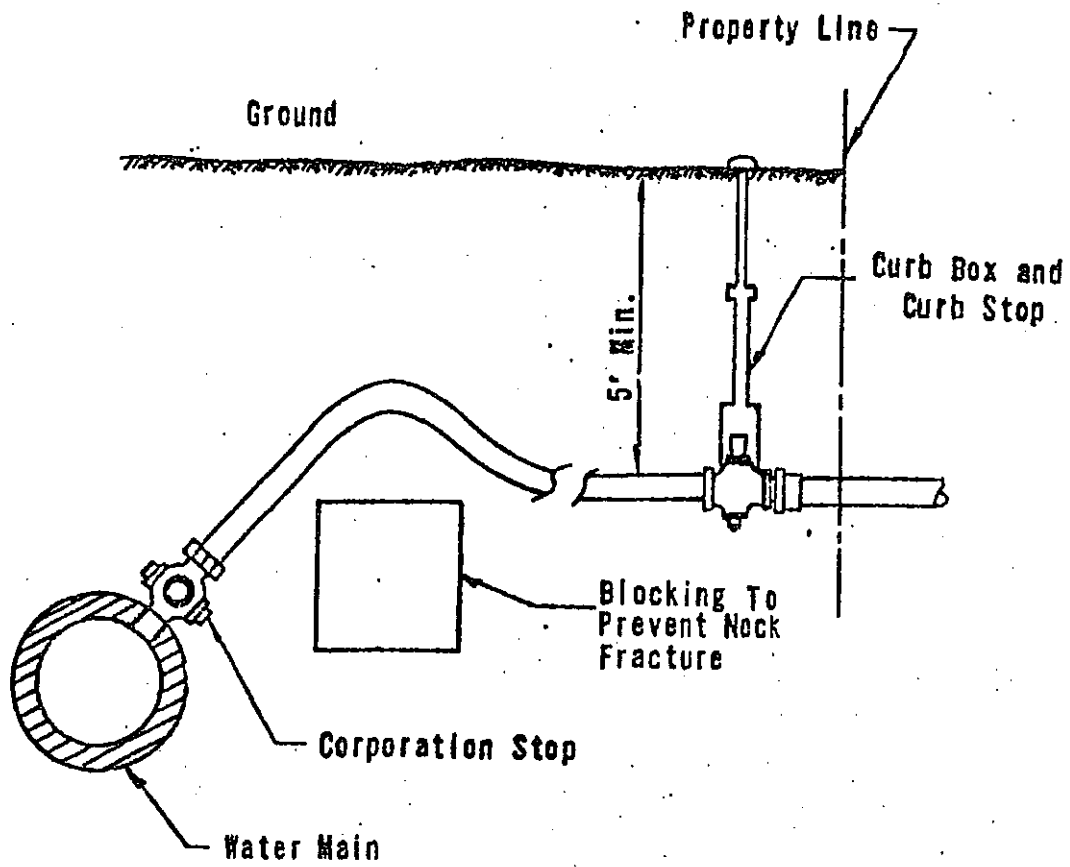

TOWN OF SARATOGA
 SUBDIVISION STANDARD DWG. 5.3

TYPICAL HOUSE WATER SERVICE

PART IV

APPROVED MATERIALS
FOR
SUBDIVISION CONSTRUCTION

Part IV - Approved Materials for Subdivision Construction

1. General Construction

1.1 Plain and Reinforced Concrete

Portland Cement	N.Y.S. D.P.W. M1 of M2
Air-Entraining Admixtures	N.Y.S. D.P.W. M21
Aggregates	N.Y.S. D.P.W. M3 & M4
Water	N.Y.S. D.P.W. M46
Bar Reinforcement for Cement Concrete	N.Y.S. D.P.W. M17
Welded Steel Wire Fabric for Concrete Reinforcement	N.Y.S. D.P.W. M17AB (ASTM A185)

1.2 Guide Railing

3 Guide Railing Posts	N.Y.S. D.P.W. M14S
	N.Y.S. D.P.W. M19
	(ASTM-A36) (ASTM-A123)
Completed Assembly with End Anchors	N.Y.S. D.P.W. Standard Drawing 67-14 (A & B)

1.3 Topsoil and Seeding

Topsoil	N.Y.S. D.P.W. M47
Seed	N.Y.S. D.P.W. Item 123A

2. Paving Construction

Gravel Base	N.Y.S. D.P.W. Item 3 & 4
Aggregate for Base Course	N.Y.S. D.P.W. Item 42, 42G, 42Q, 42S, 43, 44, 45
Bituminous Concrete Binder Course	N.Y.S. D.P.W. Item 51M (Binder Course)
Bituminous Concrete Wearing Course	N.Y.S. D.P.W. Item 51M Option No. 1 or Option No. 3 (Heated Process)
	N.Y.S. D.P.W. Item 55B Sec. 1.1 Plain & Reinforced Concrete

2. Paving Construction (cont.)

Perforated Corrugated Metal Pipe
Underdrain with Bituminous Coating

N.Y.S. D.P.W. M23D
Coating to Federal
Specification WW-P-405
Type A Coating
AASHO M197

Corrugated Aluminum Alloy Pipe
Underdrain

3. Storm Drainage System

3.1 Pipe

Concrete Storm Drain Pipe
Corrugated Steel Pipe and
Coupling Bands
Reinforced Concrete Pipe Class III,
IV, and V
Vitrified Clay Pipe
Asbestos Cement Pipe

N.Y.S. D.P.W. M22B
N.Y.S. D.P.W. M23A

N.Y.S. D.P.W. M25A

N.Y.S. D.P.W. M22C
N.Y.S. D.P.W. M22A
(ASTM C428)
AASHO M196

Corrugated Aluminum Alloy
Pipe and Coupling Bands

3.2 Pipe Joints

Flexible, Watertight Rubber
Gasket Joints for Concrete Pipe
Clay Pipe Joints
Asbestos-Cement Pipe Joints

ASTM C443

AST, C425
Manufacturer's Specifications
subject to Planning Board
Approval

3.3 Catch Basins and Manholes

Precast Concrete Manhole Section
Common Brick
Concrete Block
Concrete Brick
Mortar
Frames, Grates and Covers

AST, C478
N.Y.S. D.P.W. M43
N.Y.S. D.P.W. M44
N.Y.S. D.P.W. M44B
ASTM C270
N.Y.S. D.P.W. M8

4. Sanitary Sewer System

4.1 Pipe

Reinforced Concrete Culvert, Storm
Drain and Sewer Pipe Class III, IV
and V Containing Class II Cement
with air entraining
Vitrified Clay Pipe
Asbestos-Cement Pipe

ASTM C76

N.Y.S. D.P.W. M22C
N.Y.S. D.P.W. M22A

4.2 Pipe Joints

Flexible, Watertight Rubber Gasket
Joints for Concrete Pipe
Clay Pipe Joints
Asbestos-Cement Pipe Joints

ASTM C443

ASTM C425
Manufacturer's Specification
Subject to Planning Board
Approval

4.3 Manholes

Precast Concrete Manhole Sections
Common Brick
Concrete Block
Concrete Brick
Mortar, Type M with Air
Entrainment
Frames and Covers

ASTM C478

N.Y.S. D.P.W. M43
N.Y.S. D.P.W. M44
N.Y.S. D.P.W. M44B
ASTM C270

N.Y.S. D.P.W. M8

4.4 Services

Cast Iron Soil Pipe and Fittings
Vitrified Clay Pipe
Asbestos-Cement Pipe

ASA No. A40.1

N.Y.S. D.P.W. M22C
N.Y.S. D.P.W. M22A

5. Water System

5.1 Pipe

Asbestos-Cement Pressure Pipe-
Class 150 or greater
Cast Iron Pipe with Cement
Lining-150 psi Working Pressure
Cement Lining for Cast Iron Pipe
Reinforced Concrete Pressure Pipe

AWWA C400

ASA, A21.6 or ASA A21.8

ASA A21.4
AWWA C300, AWWA C301,
AWWA C302

5.2 Fittings

Cast Iron Fittings - Class D
with outside coating

ASA A21.10

5.3 Joints

Asbestos-Cement Joint

Manufacturer's Specification
Subject to Planning Board
Approval

Cast Iron Mechanical Joint

ASA A21.11

Cast Iron Push-On Joint

ASA A21.11

Flexible, Watertight Rubber

ASTM C443

Gasket Joint for Concrete Pipe

5.4 Gate Valves

Cast Iron Body, Bronze Mounted
Double Disc, Hub End Non-Rising
Stem, Square Operating Nut,
Opening Left, Rensselaer 13A

AWWA C500

5.5 Hydrants

Five Inch Size with Two - 2½"
Hose Nozzles and One - 4" Steamer
Nozzle; National Standard Threads;
Six Inch Hub Connection and Five
Foot Bury; Pentagon Operating Nut
Opening Left - Rensselaer L-90B

AWWA C502

5.6 Valve Boxes

Cast Iron Screw Type; "W" or
"Water" Cast in the top; the
Standard Catalog Product of a
Reputable Manufacturer

5.7 House Services

Corporation Stop
Curb Stop (Open Left)
Curb Box
Copper Tubing Type K

As Approved by Board
As Approved by Board
As Approved by Board
ASTM B88

5.8 House Meters

Rockwell 5/8" X 3/4", Sealed
Register, Magnetic Drive Recording in Gallons

